

# SD8 (2-POLE) AC motor

Ø96 mm frame // 37 mm stack

all dimensions in mm

**parvalux**  
by **maxon**

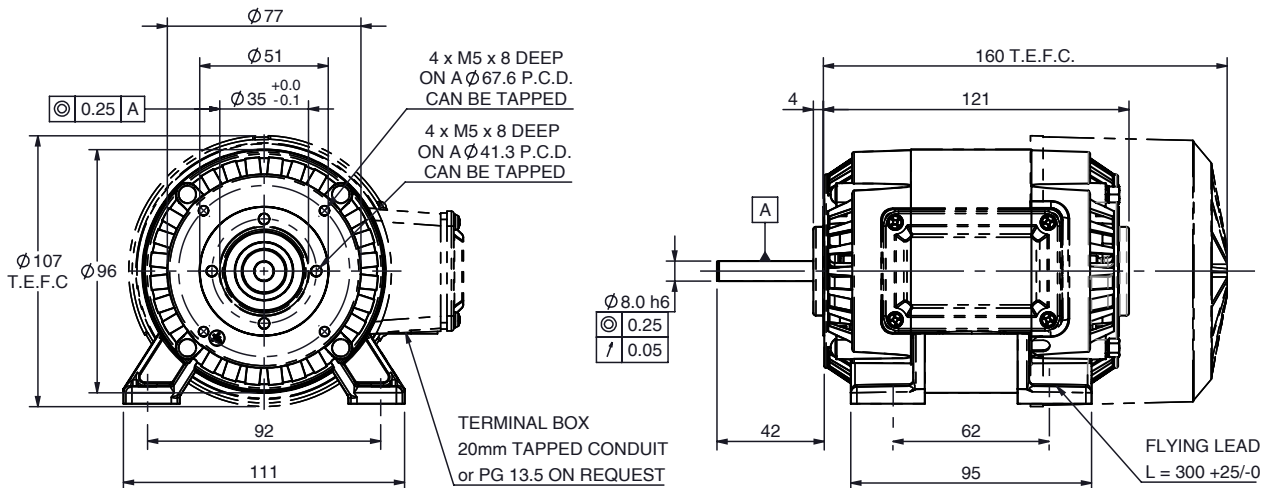

## Part number key

Modular	#####
Standard	#####
Calculated data	#####

Please see our customisation options page for details on the modifications available on our products. Advice and guidance on these options are available from your local sales engineer.

**Note:** Terminal box and feet optional on this motor - please contact your local sales engineer for more information. Totally enclosed fan cooled (TEFC) option also available

## Technical data

1 Part number		-	-		
2 Phases		1	1	3	3
3 Frequency	Hz	50	60	50	60
4 Nominal voltage	V AC	230/115	230/115	400/230	400/230
5 Nominal power	W	60	60	60	60
6 Nominal speed	rpm	2800	3400	2800	3400
7 Nominal continuous torque (S1)	Nm	0.20	0.17	0.20	0.17
8 Nominal continuous current (S1)	A	0.57	-	0.24	-
9 Starting Current	A	1.42	0	0.60	0
10 Input power	W	127	127	105	105
11 Capacitor Value	M.F.D	4.0	4.0/14.0	-	-
12 Starting torque full load	%	75	75	200	200
13 Stack length	mm	37	37	37	37
14 Number of poles		2	2	2	2
15 Rotor inertia	Kg/cm <sup>2</sup>	-	-	-	-

## Thermal data

16 Ambient temperature	°C	40
------------------------	----	----

## Mechanical data

17 Radial load [distance from flange]	N [mm]	150 [15]
---------------------------------------	--------	----------

## Other data

18 Weight	Kg	2.8
19 Enclosure		VENT/TE
20 IP Rating - Ventilated		IP20
21 IP Rating - TE/TEFC		IP54
22 Insulation Class		F
23 Type		Permanent capacitor, asynchronous
24 Direction		Reversible

## Compatible products

Gearbox	Page #	Brake	Page #
S Box	216	1.5 Nm	258
GB28	218	2.0 Nm	259
GB58	219		
M Box	222		
MWS	230		
GB36	231		
LIW	242		
PGx52	249		
LIS	244		
LWS	236		

Encoder	Page #
On request	-

## Key

Standard combination

Modular combination

# SD8 (2-POLE) combinations

Quickview - combination drawing and technical data

**parvalux**  
by **maxon**

Combination drawing		Technical data							
SD8-S-Box		Gear material <sup>1</sup>	Comp.	Comp.	Comp.	Bronze	Bronze	Bronze	
		Gear ratio <sup>2</sup>	:1	4	30	70	4	30	70
		Speed <b>rpm</b>	850.0	113.3	48.6	850.0	113.3	48.6	
		Nominal torque <b>Nm</b>	0.5	3.0	2.0	0.5	2.9	3.0	
SD8-GB28		Gear material <sup>1</sup>	Comp.	Comp.	Comp.	Bronze	Bronze	Bronze	
		Gear ratio <sup>2</sup>	:1	-	-	-	15	30	60
		Speed <b>rpm</b>	-	-	-	226.7	113.3	56.7	
		Nominal torque <b>Nm</b>	-	-	-	1.9	3.3	4.6	
SD8-GB58		Gear material <sup>1</sup>	Comp.	Comp.	Comp.	Bronze	Bronze	Bronze	
		Gear ratio <sup>2</sup>	:1	4	15	25	-	-	-
		Speed <b>rpm</b>	850.0	226.7	136.0	-	-	-	
		Nominal torque <b>Nm</b>	0.6	1.9	2.9	-	-	-	
SD8-M-Box		Gear material <sup>1</sup>	Comp.	Comp.	Comp.	Bronze	Bronze	Bronze	
		Gear ratio <sup>2</sup>	:1	4	30	72	4	30	72
		Speed <b>rpm</b>	850.0	113.3	47.2	850.0	113.3	47.2	
		Nominal torque <b>Nm</b>	0.6	3.6	5.0	0.5	3.1	4.9	
SD8-MWS		Gear material <sup>1</sup>	Comp.	Comp.	Comp.	Bronze	Bronze	Bronze	
		Gear ratio <sup>2</sup>	:1	24	120	1400	-	-	-
		Speed <b>rpm</b>	141.7	28.3	2.4	-	-	-	
		Nominal torque <b>Nm</b>	3.1	15.1	45.0	-	-	-	
SD8-GB36		Gear material <sup>1</sup>	Comp.	Comp.	Comp.	Bronze	Bronze	Bronze	
		Gear ratio <sup>2</sup>	:1	24	120	1400	-	-	-
		Speed <b>rpm</b>	141.7	28.3	2.4	-	-	-	
		Nominal torque <b>Nm</b>	3.1	15.1	45.0	-	-	-	
SD8-LTW		Gear material <sup>1</sup>	Comp.	Comp.	Comp.	Bronze	Bronze	Bronze	
		Gear ratio <sup>2</sup>	:1	36	400	1200	36	400	1200
		Speed <b>rpm</b>	94.4	8.5	2.8	94.4	8.5	2.8	
		Nominal torque <b>Nm</b>	4.5	28.0	28.0	4.5	40.1	45.0	
SD8-PGX62		Gear material <sup>1</sup>	Comp.	Comp.	Comp.	Bronze	Bronze	Bronze	
		Gear ratio [stages] <sup>2</sup>	:1	-	-	-	3.9 [1]	44 [2]	172 [3]
		Speed <b>rpm</b>	-	-	-	871.8	77.3	19.8	
		Nominal torque <b>Nm</b>	-	-	-	0.6	6.9	26.0	
SD8-LIS		Gear material <sup>1</sup>	Comp.	Comp.	Comp.	Bronze	Bronze	Bronze	
		Gear ratio <sup>2</sup>	:1	6	50	115	-	-	-
		Speed <b>rpm</b>	566.7	68.0	29.6	-	-	-	
		Nominal torque <b>Nm</b>	0.8	6.5	15.1	-	-	-	
SD8-LWS		Gear material <sup>1</sup>	Comp.	Comp.	Comp.	Bronze	Bronze	Bronze	
		Gear ratio <sup>2</sup>	:1	48	672	3450	-	-	-
		Speed <b>rpm</b>	70.8	5.1	1.0	-	-	-	
		Nominal torque <b>Nm</b>	5.5	74.3	100.0	-	-	-	

## Key

Standard combination / standard gear ratio

**Modular combination / modular gear ratio**

## Notes

<sup>1</sup> Comp. = Composite gears

<sup>2</sup> Full gear ratio options displayed on individual gearbox datasheets

→ Technical data displayed above calculated based on **SD8 (2-POLE) 3 Phase 60Hz** motor.

→ Simplified drawings displayed above show overall envelope size of the combination. Please see individual motor and gearbox datasheets for detailed technical drawings.