

SD11 (SHUNT) AC/DC motor

Ø99 mm frame

all dimensions in mm

parvalux
by **maxon**

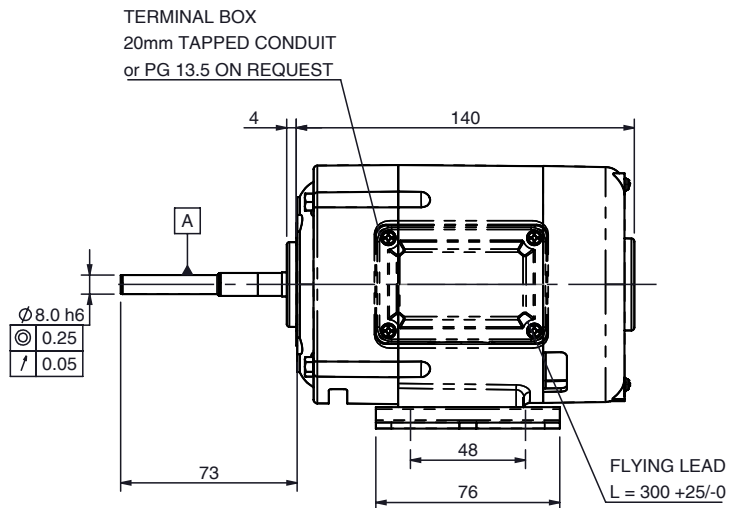
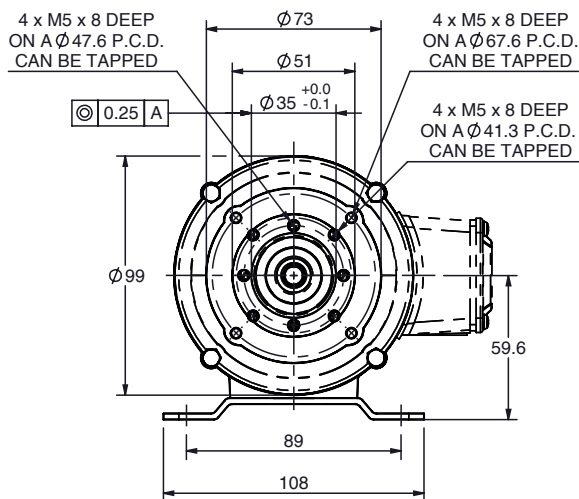

Part number key

Modular	#####
Standard	#####
Calculated data	#####

Please see our customisation options page for details on the modifications available on our products. Advice and guidance on these options are available from your local sales engineer.

Note: Terminal box and feet optional on this motor - please contact your local sales engineer for more information.

Technical data

1 Part number		-	-	-
2 Minimum voltage available	V	12	12	12
3 Nominal power	W	50	95	125
4 Nominal speed	rpm	2000	3000	4000
5 Nominal continuous torque (S1)	Nm	0.24	0.30	0.30
6 Input current 240 V AC	A	0.40	0.70	0.90
7 Input current 220 V AC	A	0.45	0.75	1.00
8 Approximate starting current ¹	A	3 x F.L.	3 x F.L.	3 x F.L.
9 Input power	W	96	168	216

¹3 x F.L. = 3 x Full Load

Thermal data

10 Ambient temperature	°C	40
------------------------	-----------	----

Mechanical data

11 Radial load [distance from flange]	N [mm]	200 [15]
---------------------------------------	---------------	----------

Other data

12 Weight	Kg	2.5
13 Enclosure		VENT/TENC
14 IP Rating - Ventilated		IP23
15 IP Rating - TENC [with terminal box]		IP50 [IP54]
16 Insulation Class		F
17 Type		Shunt wound
18 Direction		Reversible

Compatible products

Gearbox	Page	Brake	Page #
M Box	222	1.5 Nm	258
L Box	226	2.0 Nm	259
MWS	230		
LIW	242		
LIS	244		
LWS	236		

Encoder	Page #
On request	-

Key

Standard combination
Modular combination

SD11 (SHUNT) combinations

Quickview - combination drawing and technical data

parvalux
by **maxon**

Combination drawing		Technical data							
SD11-M-Box		Gear material ¹	Comp.	Comp.	Comp.	Bronze	Bronze	Bronze	
		Gear ratio ²	:1	4	30	72	4	30	72
		Speed rpm	1000.0	133.3	55.6	1000.0	133.3	55.6	
		Nominal torque Nm	1.0	6.3	5.0	0.9	5.5	8.0	
SD11-L-Box		Gear material ¹	Comp.	Comp.	Comp.	Bronze	Bronze	Bronze	
		Gear ratio ²	:1	5	30	60	5	30	60
		Speed rpm	800.0	133.3	66.7	800.0	133.3	66.7	
		Nominal torque Nm	1.4	6.5	9.9	1.3	5.9	8.1	
SD11-MWS		Gear material ¹	Comp.	Comp.	Comp.	Bronze	Bronze	Bronze	
		Gear ratio ²	:1	24	120	1400	-	-	-
		Speed rpm	166.7	33.3	2.9	-	-	-	
		Nominal torque Nm	5.5	22.0	45.0	-	-	-	
SD11-LWS		Gear material ¹	Comp.	Comp.	Comp.	Bronze	Bronze	Bronze	
		Gear ratio ²	:1	36	400	1200	36	400	1200
		Speed rpm	111.1	10.0	3.3	111.1	10.0	3.3	
		Nominal torque Nm	8.0	28.0	28.0	8.0	45.0	45.0	
SD11-LIS		Gear material ¹	Comp.	Comp.	Comp.	Bronze	Bronze	Bronze	
		Gear ratio ²	:1	6	50	115	-	-	-
		Speed rpm	666.7	80.0	34.8	-	-	-	
		Nominal torque Nm	1.4	11.6	26.6	-	-	-	
SD11-LWS		Gear material ¹	Comp.	Comp.	Comp.	Bronze	Bronze	Bronze	
		Gear ratio ²	:1	48	672	3450	-	-	-
		Speed rpm	83.3	6.0	1.2	-	-	-	
		Nominal torque Nm	9.8	100.0	100.0	-	-	-	

Key

Standard combination / standard gear ratio

Modular combination / modular gear ratio

Notes

¹ Comp. = Composite gears

² Full gear ratio options displayed on individual gearbox datasheets

→ Technical data displayed above calculated based on **SD11 (SHUNT) 12V 4000 rpm** motor.

→ Simplified drawings displayed above show overall envelope size of the combination. Please see individual motor and gearbox datasheets for detailed technical drawings.