

Modular Range Guide 2025



Gearbox

Combined with our modular motors through use of a simple mounting flange, our gearbox range offers a range of gear ratios and comes as standard with a hollow shaft.

Motor

With options in both motor voltage and output speed, you can configure your DC brushed or DC brushless motor to meet your exact performance requirements.

Encoder

Add our incremental encoder to your modular configuration to enable further control to the power supply of your system.

Brake

Intelligently designed to fit around our encoders through use of a mounting flange, our 1.5 Nm brakes combine seamlessly with our modular range motors.



Controller

Our Parvalux controller, designed with parent company maxon, offers precise control with both our PMDC and BLDC motors.

Shaft

Secured through a keyway and slot, our shaft extension kits offer a quick-fit solution where a hollow shaft isn't quite right for your application.

Available in quantities of up to **10 pieces**

Simply Modular

Quick to configure. Quick to build. Quick to deliver.

Configure your own solution online; selecting your motor and gearbox, and adding accessories such as encoders, brakes, controllers, and shaft extension kits to create a solution perfectly suited to your specific application.

Visit www.parvalux.com to build your own solution through our online product configurator.

Easy as one two three

 Our expert team of engineers have extensive experience in specifying Parvalux products for a wide range of applications, contact them today if you require any assistance.

Step 1.

Determine your required output performance.

Every application can vary, however the main factors to consider when selecting a motor-gearbox combination are voltage, speed, and torque.

Our modular range caters for voltages of 12 - 48V, up to 4500 rpm speed, and between 0.063 - 80.0 Nm of torque.

Step 2.

Select your motor and gearbox combination.

Gearboxes enable you to reduce the output speed of your motor, whilst also increasing the torque. However, we also offer motor only solutions where very high speed and low torque is required.

Further details on the output performance of each combination within the modular range can be found throughout the rest of this guide.

Step 3.

Fine tune your selection and order your modular solution.

Our range of accessories include brakes, encoders, controllers, and shaft extension kits, enabling you to tailor your selection to your application.

Once you've created a solution that matches your requirements, contact the Parvalux team to order in quantities of up to 10 pieces.

 Build and order your own combination using our online configurator, scan the QR code to get started.



Other pages	Page
→ Accessories	50 - 57
→ Market recommendations	58 - 63
→ Next steps	64 - 65
→ Contact	66 - 67

Product type	Page
Motor only	6 - 11
Gearbox only	12 - 17
Combinations	18 - 49

Motor Specifications

Quickview

The next few pages display a quick view of the specifications of each of the motors within the modular range. Voltage, power, and torque are the best starting points in motor selection as these provide the basis for the output performance of DC motors.

Within our range you'll find both brushed and brushless options at different frame sizes and stack lengths. Generally, the larger the frame size, the more powerful the motor, however, there is some cross-over between the varying stack lengths of similar sized motors.

For a more detailed specification of each motor please refer to the datasheets and product range catalogue found at parvalux.com



Voltage Key

- Available
- Currently unavailable

BLDC	12V	24V	48V	Output speed (rpm)
PBL42-15	●	●	●	0 - 4000
PBL42-35	●	●	●	0 - 4000
PBL60-50	●	●	●	0 - 3000
PBL60-70	●	●	●	0 - 3000
PBL70-70	●	●	●	0 - 4500
PBL70-80	●	●	●	0 - 4500
PBL86-55	●	●	●	0 - 4000
PBL86-80	●	●	●	0 - 4000

PMDC	12V	24V	48V	Output speed (rpm)
RE38-25	●	●	●	0 - 3500
RE38-40	●	●	●	0 - 3500
BRx42-25	●	●	●	0 - 3000
BRx42-40	●	●	●	0 - 3000
BRx52-30	●	●	●	0 - 3000
BRx52-58	●	●	●	0 - 3000
BRx63-25	●	●	●	0 - 2500 @ 12V
BRx63-55	●	●	●	0 - 2800 @ 12V
BRx70-40	●	●	●	0 - 3000
BRx70-60	●	●	●	0 - 3000
BRx90-50	●	●	●	0 - 3000
BRx90-75	●	●	●	0 - 3000

Motors in the modular range are currently only available in the speed shown above. Our standard motors can be custom wound to meet your speed and voltage requirements.

Motor Specifications

Power

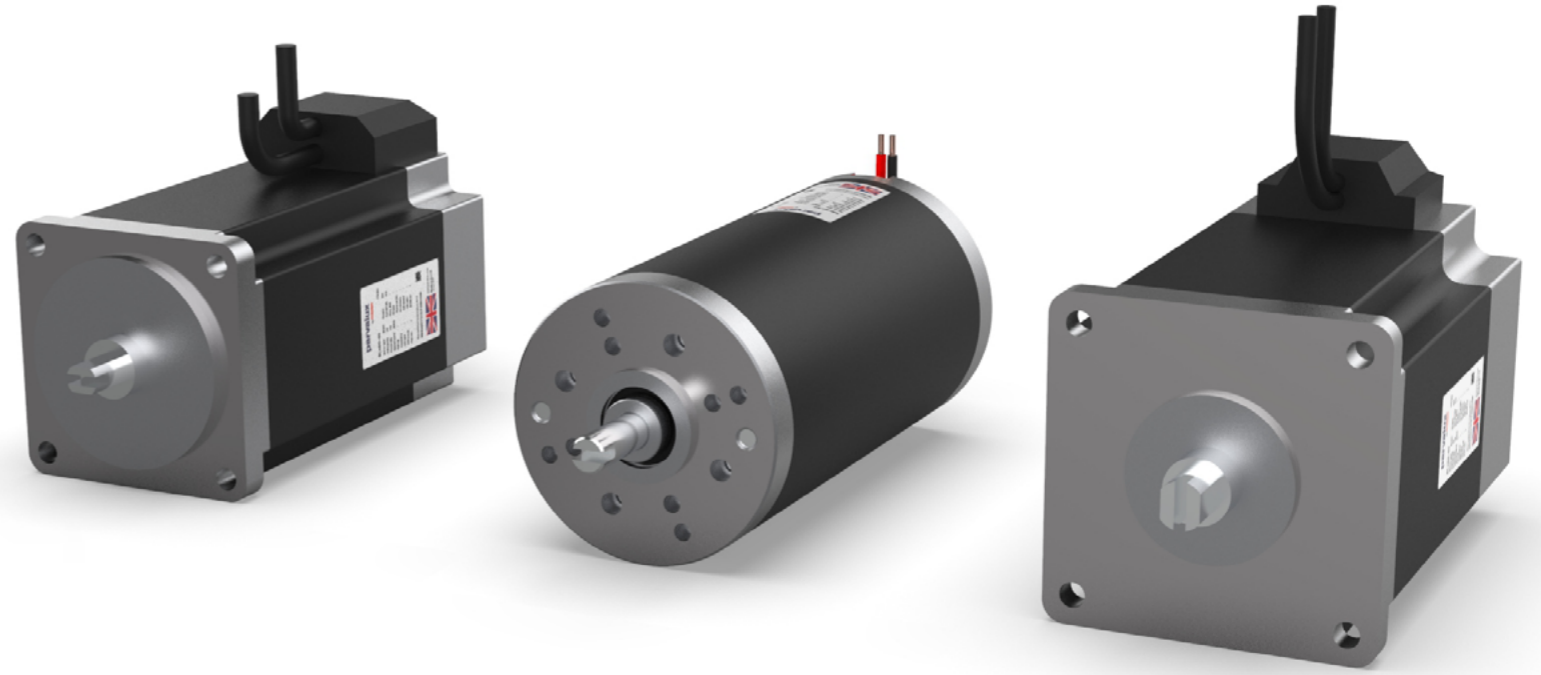

Nominal power, measured in Watts (W), represents the mechanical output power that the motor is capable of producing in continuous operation. It is calculated based on the motors speed and torque.

BLDC Power



PMDC Power



Motor Specifications

Torque

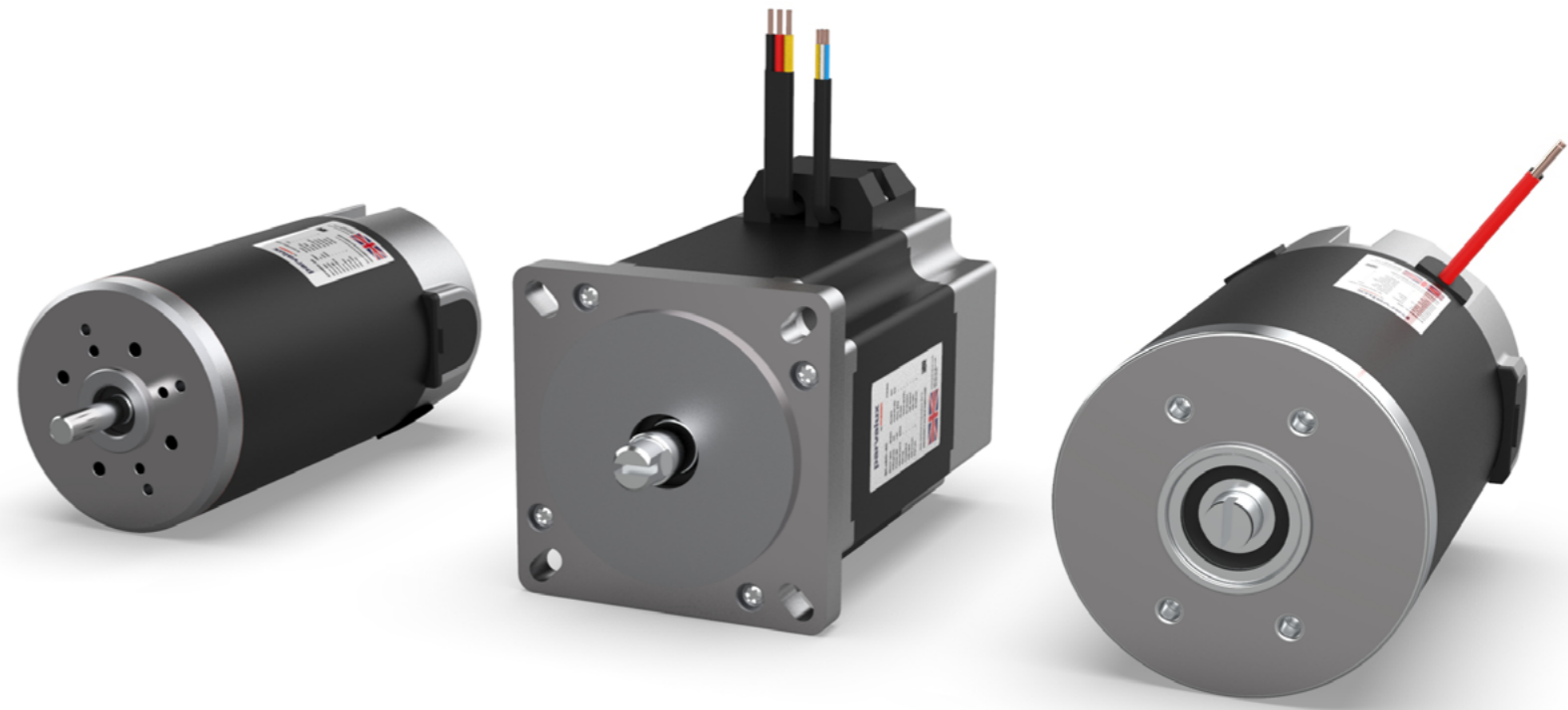

Rated torque (Nm) refers to the maximum torque that the motor can generate while operating continuously in an ambient temperature of 40°C.

BLDC Torque

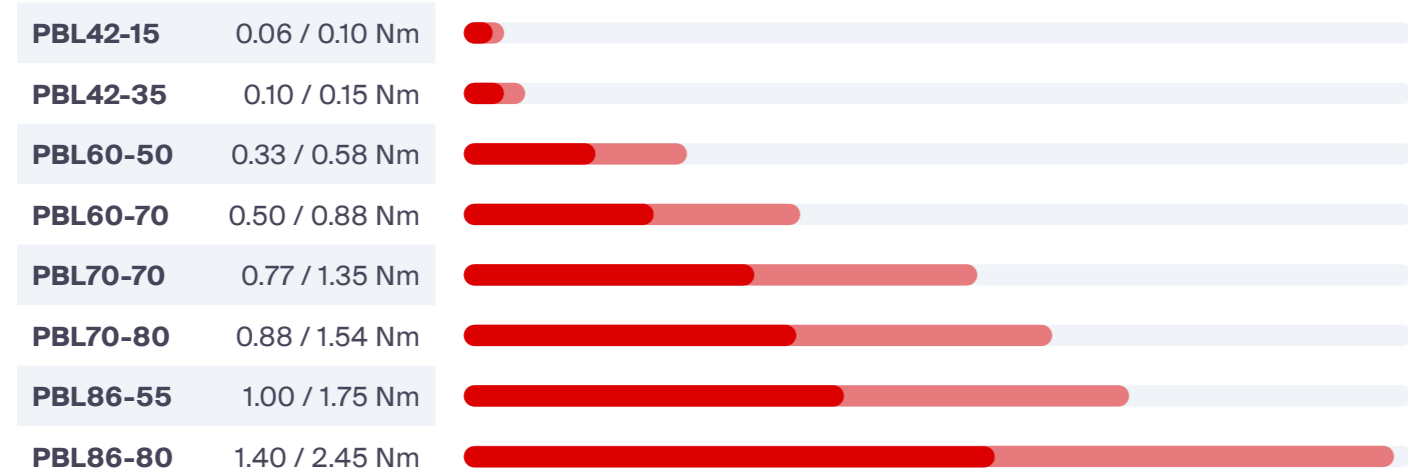

PMDC Torque



There are two values shown for torque; these represent the max. continuous torque and max. intermittent torque (S2 - 15 minutes) of each motor. These are also depicted by the darker and lighter bars on the sliders above.

Gearbox Specifications

Quickview

Gearboxes enable the output speed of a motor to be reduced and the torque to be increased. These changes can have a big effect on the final output performance of the combination that you select to power your application.

 Intermittent torque rated at S2 - 15 minutes duty cycle.

Gear material

Bronze 

Steel 

Composite 

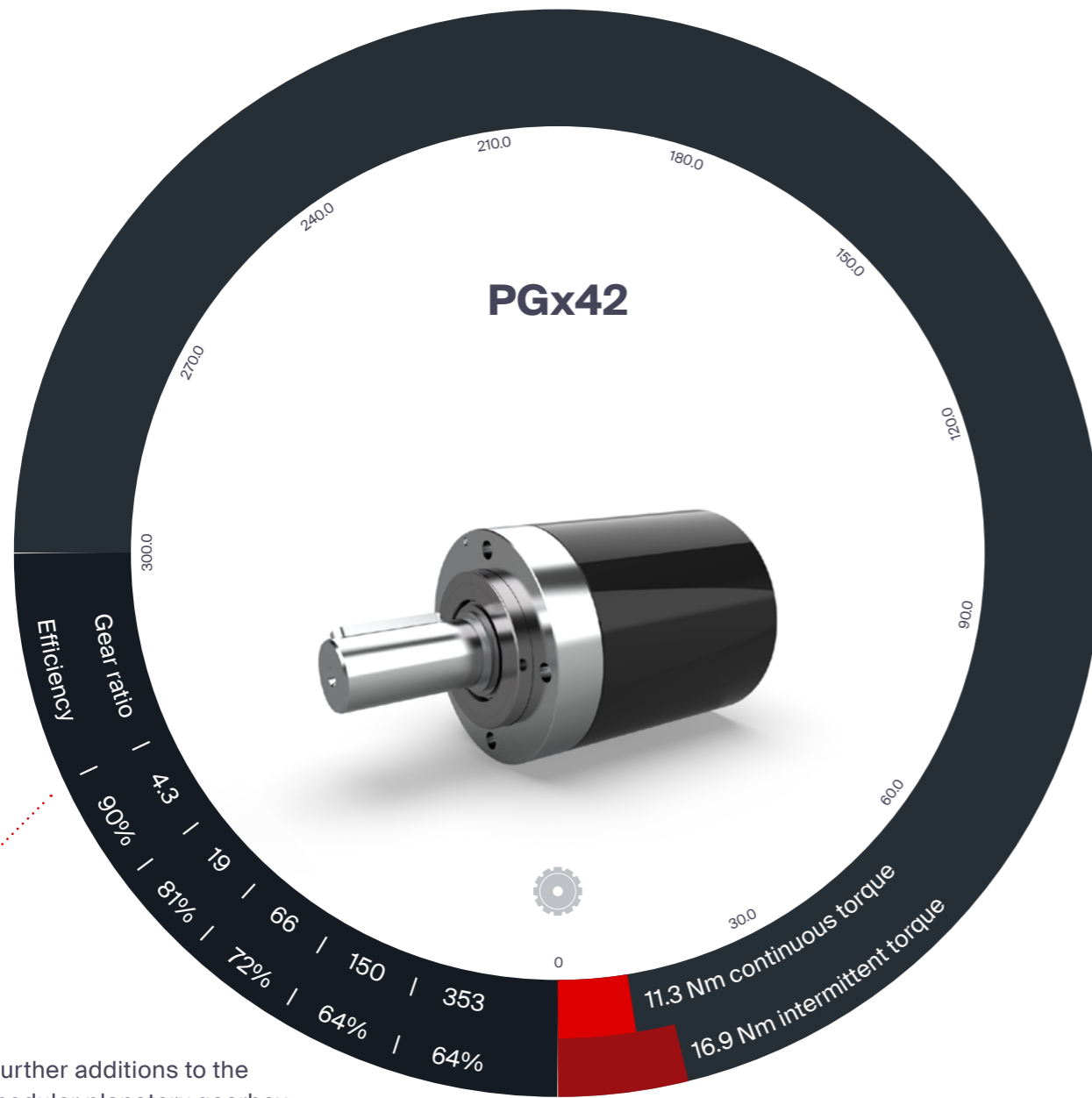

 Further additions to the modular planetary gearbox range will be added in the near future

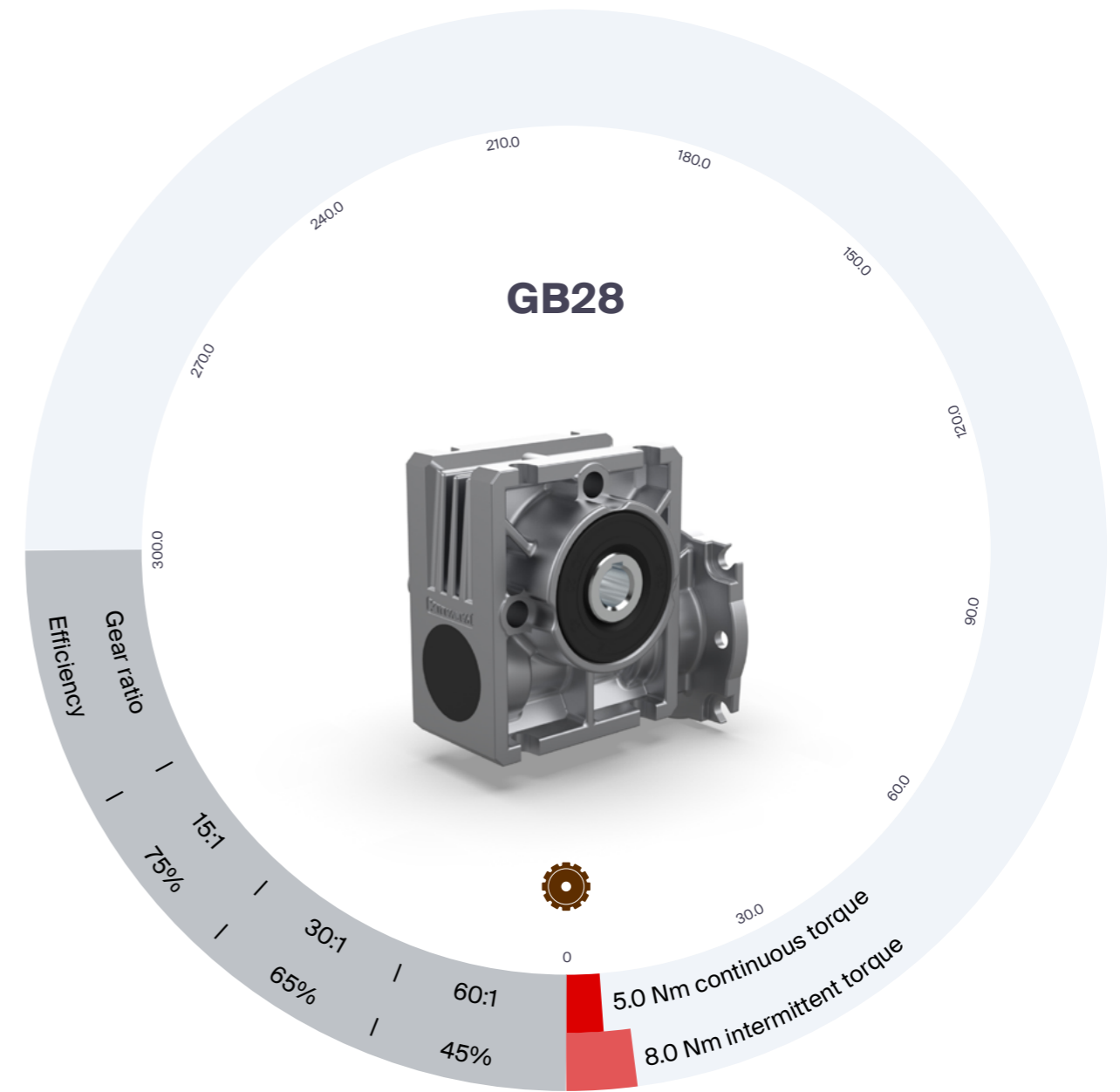

Gearbox Specifications

Quickview

Gearboxes enable the output speed of a motor to be reduced and the torque to be increased. These changes can have a big effect on the final output performance of the combination that you select to power your application.

 Intermittent torque rated at S2 - 15 minutes duty cycle.

Gear material

Bronze 

Steel 

Composite 

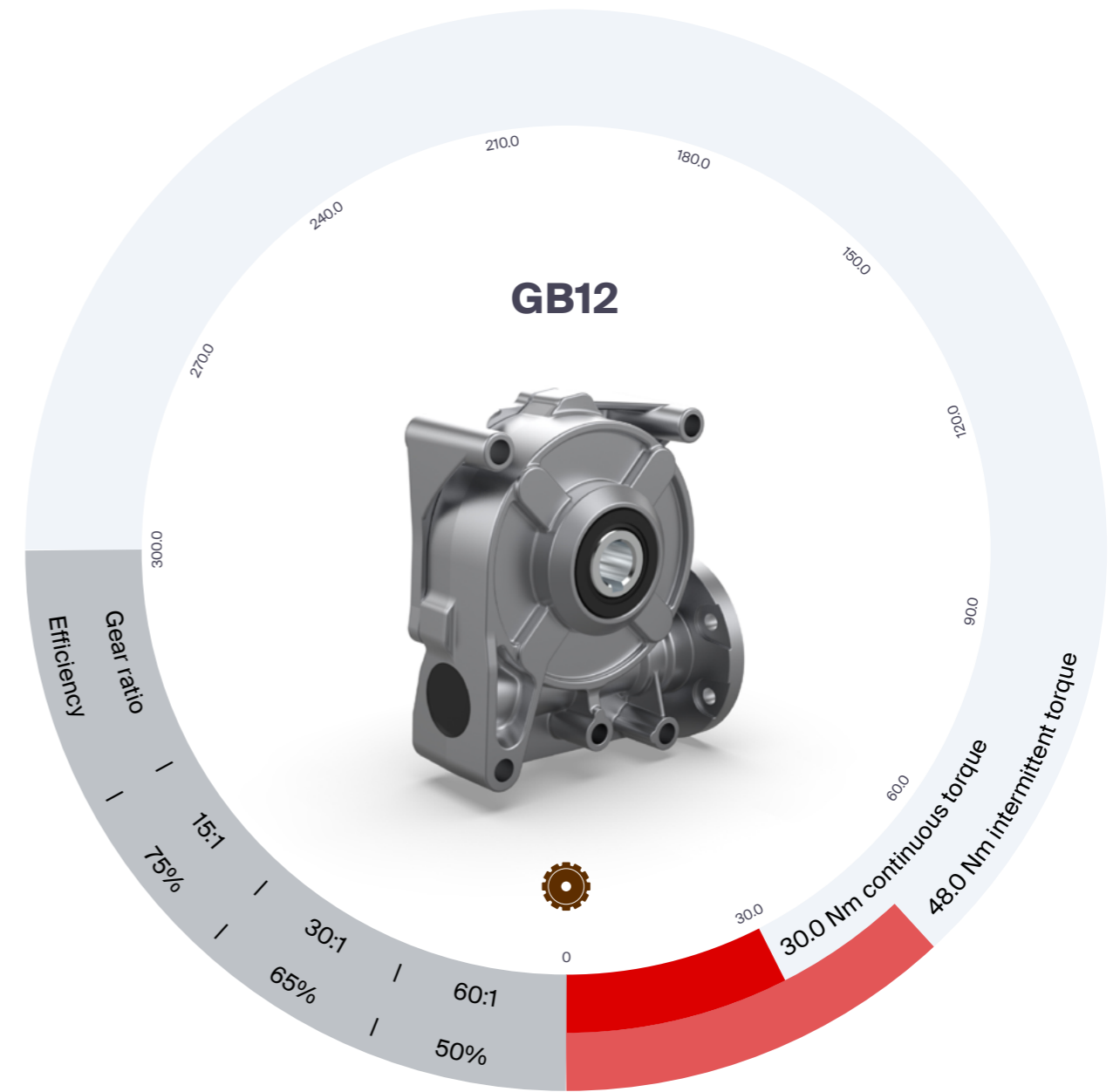

Gearbox Specifications

Quickview

Gearboxes enable the output speed of a motor to be reduced and the torque to be increased. These changes can have a big effect on the final output performance of the combination that you select to power your application.

💡 Intermittent torque rated at S2 - 15 minutes duty cycle.

Gear material

Bronze 

Steel 

Composite 

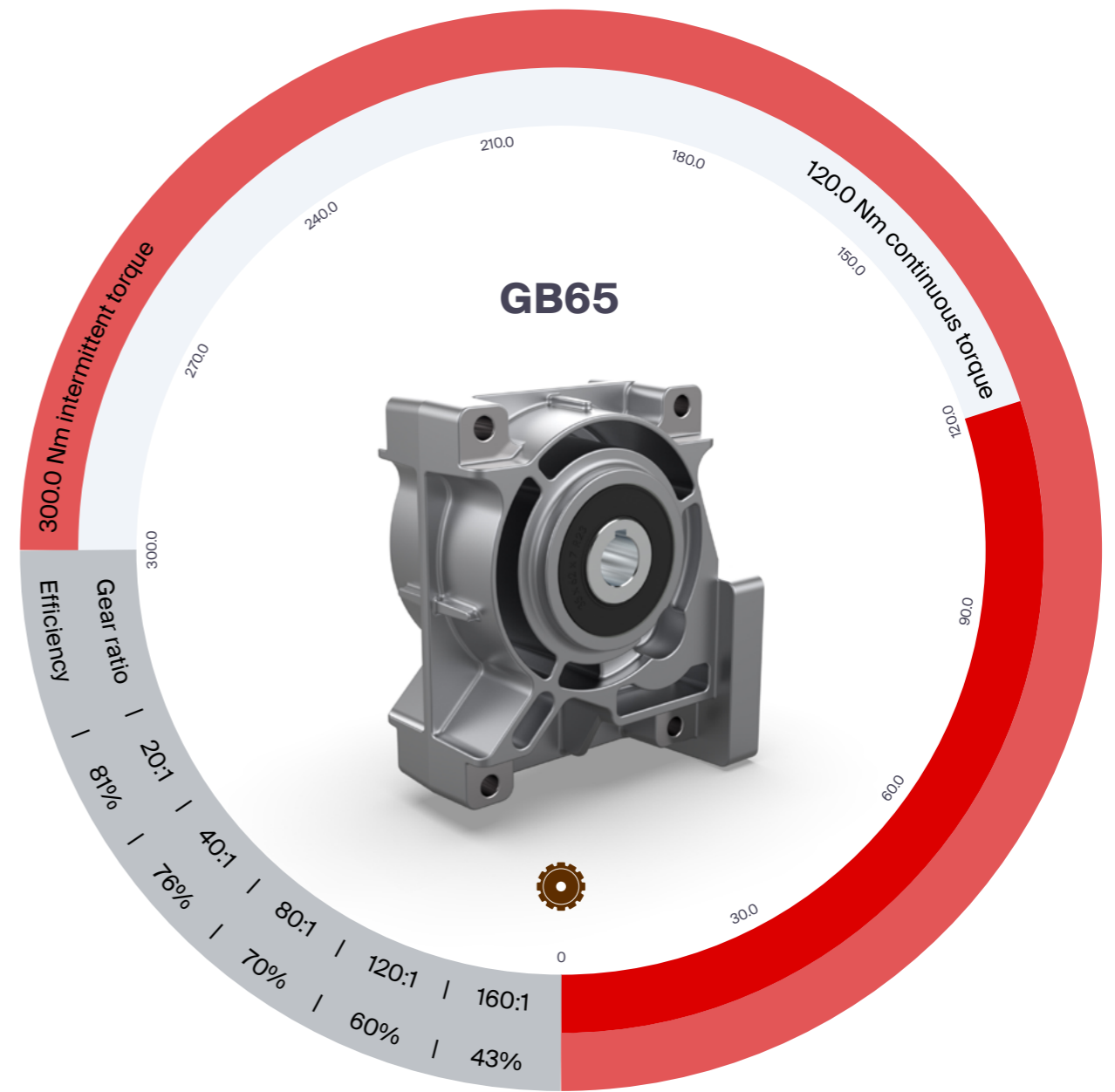
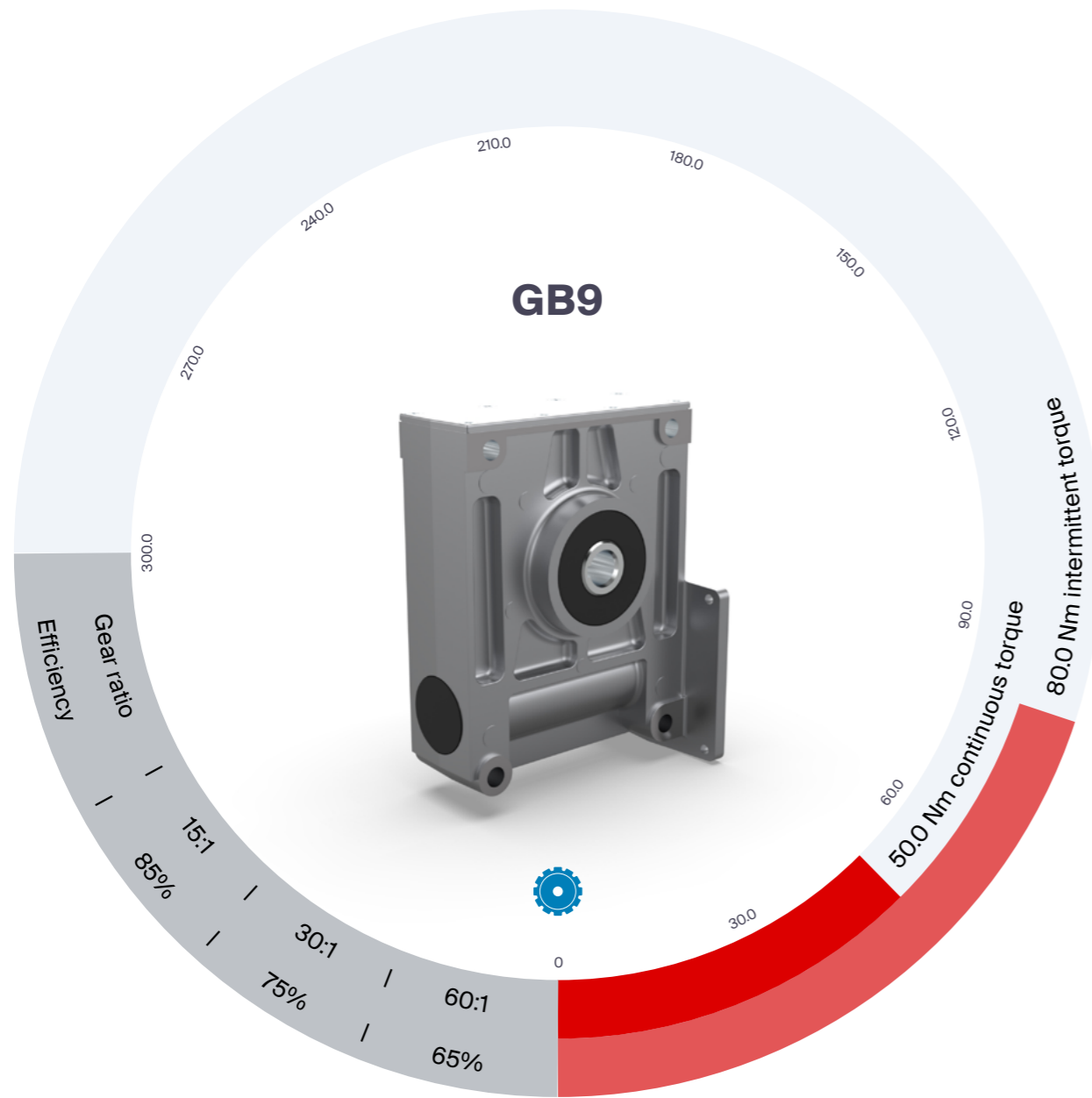

Modular matrix

A quick view of which modular motors, gearboxes and accessories are compatible with each other.

Motor	Right-angle gearboxes					Inline gearboxes		Accessories				
	GB28	GB80	GB12	GB9	GB65	PGx42	PGx52	PGx70	Encoder	Brake	Encoder + Brake	Controller
PBL42	781249					875216			781280			---
PBL60	781251	854740	781252				in development	in development	---	---	781281	---
PBL70			781255				in development	in development	---	---	781281	---
PBL86			781260	781261	781261		in development	in development	---	---	781284	---
RE38						865932			781275			---
BRx42						865932			781275			---
BRx52		854737					865939	865939	837660			---
BRx63	781239	854739					865972	865972	781276	781276	865630	---
BRx70		854737	781242				865900	865900	---	---	781277	---
BRx90			781244	781247	781247		865812	865812	---	---	781279	---
Shaft kit	735908	860809	735903	735898	854742							

Key	#####	Compatible combination of motor and gearbox (number within this signifies the mounting flange needed between the components)
	#####	Compatible shaft extension kit for the listed gearbox (number within this signifies the part number for the shaft kit)

Key	#####	Compatible accessory for the listed motor (number within this signifies the mounting flange required between the two components)
	---	Compatible accessory for the listed motor (no mounting flange required where '---' is displayed)



Modular Selection Guide

Quick view of the torque output of the modular range combinations

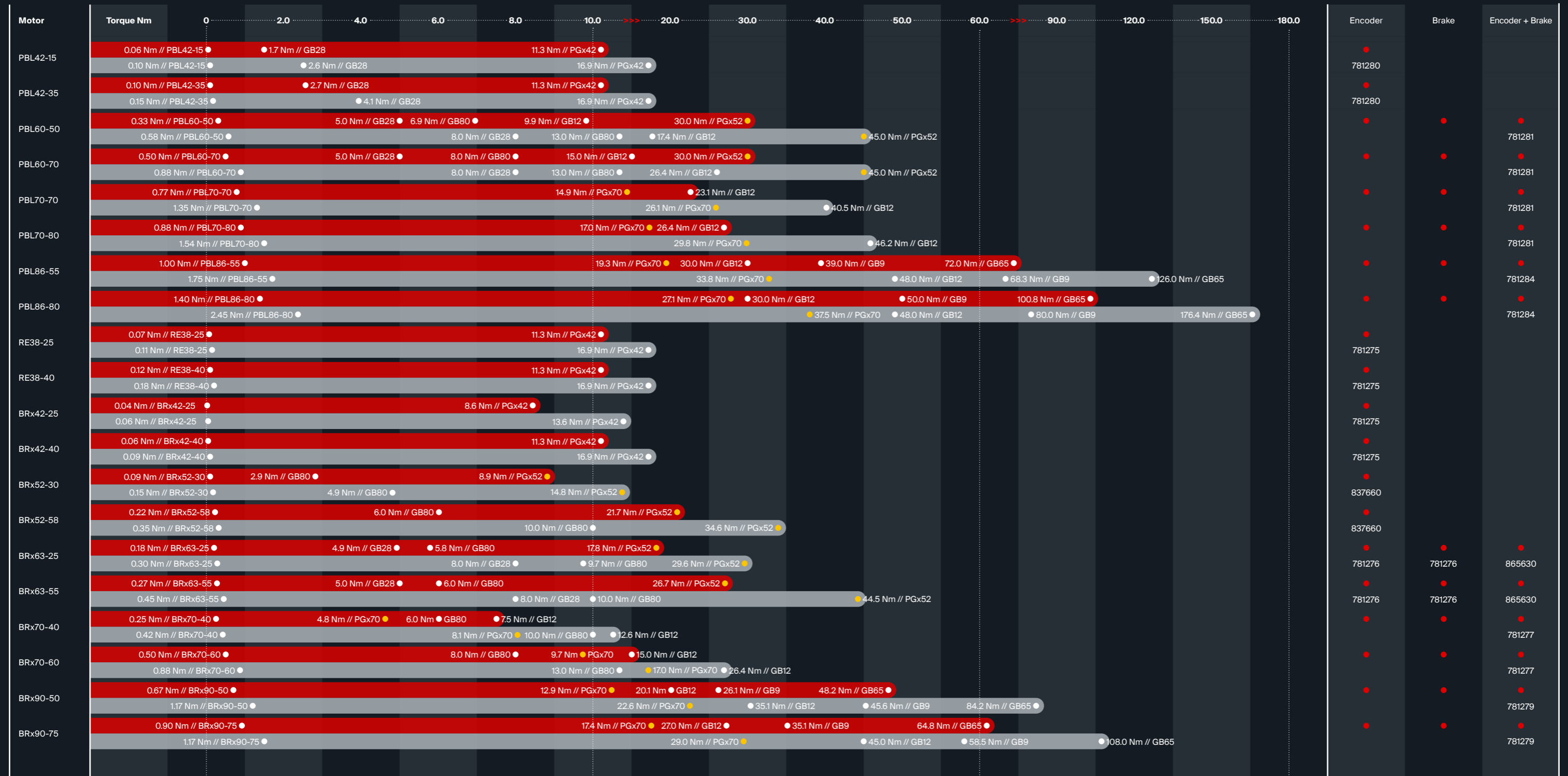

Key

- Nominal torque ¹ (Red dot)
- Intermittent torque (S2 - 15 minutes) (Yellow dot)
- motor / combination max. torque marker (Arrow)
- available now (Red background)
- in development (Yellow background)

¹ Continuous torque for motor-gearbox combinations can be calculated using the equations found on the thermal ratings page in this catalogue (page 255)

Key

- accessory available (Red dot)
- ##### (Mounting flange part number)

When mounting flange part number is not shown under dot, accessory mounts directly to the motor

PGx42 combinations

Our PGx42 planetary gearbox can be integrated with our RE38, BRx42, and PBL42 modular motors.

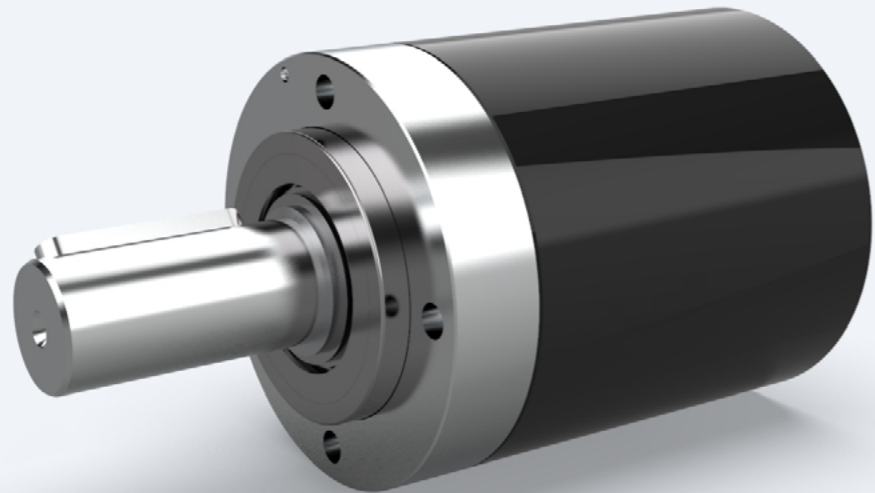

RE38-PGx42 PMDC planetary geared motor

all dimensions in mm

24 - 48 V // 24 - 40 W // 9 - 756 rpm // 0.3 - 16.9 Nm

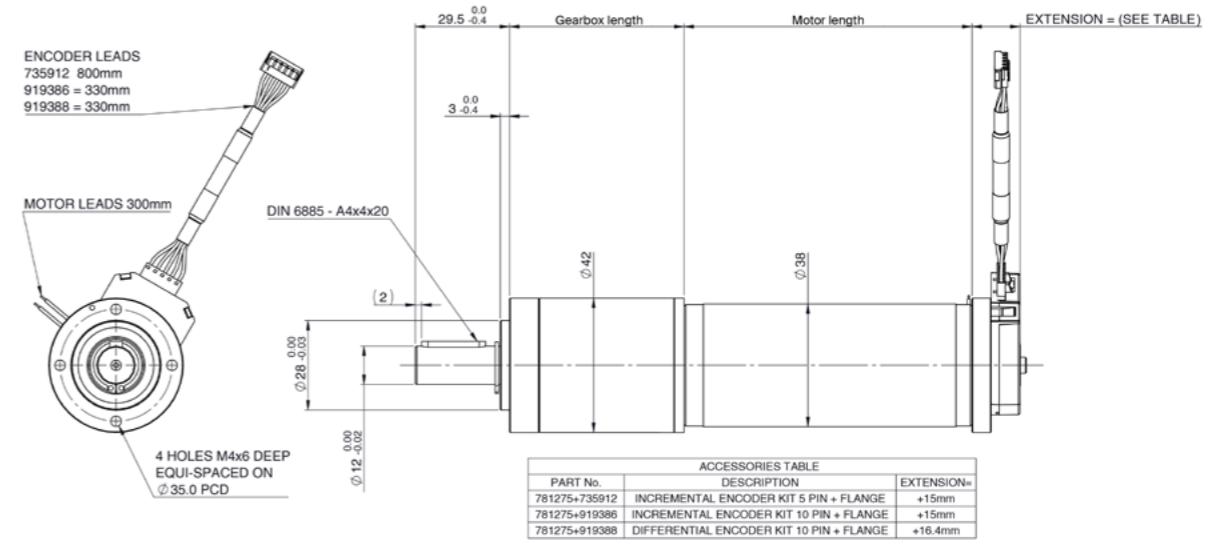

Combination data											
Motor		RE38-25	RE38-25	RE38-25	RE38-25	RE38-25	RE38-40	RE38-40	RE38-40	RE38-40	RE38-40
Voltage	V	24-48	24-48	24-48	24-48	24-48	24 - 48	24 - 48	24 - 48	24 - 48	24 - 48
Nominal motor power	W	24	24	24	24	24	40	40	40	40	40
Gearbox ratio	:1	4.3	19	66	150	353	4.3	19	66	150	353
Nominal speed	rpm	756	171	49	22	9	744	168	48	21	9
Continuous torque (S1)	Nm	0.3	1.1	3.3	6.7	11.3	0.5	1.8	5.7	11.3	11.3
Intermittent torque (S2 - 15 mins)	Nm	0.4	1.7	5.2	10.6	16.9	0.7	2.8	8.6	16.9	16.9

Motor data					
Part number		857662	857663	857664	857665
Nominal power	W	24	24	40	40
Nominal voltage	V	24	48	24	48
Nominal speed	rpm	3250	3250	3200	3200
Continuous torque (S1)	Nm	0.07	0.07	0.12	0.12
Intermittent torque (S2 - 15 minutes)	Nm	0.11	0.11	0.18	0.18
Weight	Kg	0.30	0.30	0.40	0.40
Stack length	mm	25	25	40	40
Motor length	mm	70	70	90	90

Gearbox data						
Part number		891037	891038	891039	891040	891041
Ratio	:1	4.3	19	66	150	353
Stage		1	2	3	4	4
Max. continuous torque (S1) ¹	Nm	2.3	5.6	11.3	11.3	11.3
Max. intermittent torque	Nm	3.4	8.5	16.9	16.9	16.9
Efficiency	%	90	81	72	64	64
Max. axial load (dynamic)	N	150	150	150	150	150
Max. radial load, 12mm from flange	N	120	240	360	360	360
Weight	Kg	0.26	0.36	0.46	0.56	0.56
Gearbox length	mm	37.3	51.8	66.3	80.8	80.8
Gear material		Steel	Steel	Steel	Steel	Steel

¹ S1 duty cycle based on 3000rpm input speed

Combination accessories							
Brake	Part number	Encoder	Part Number	Controller	Part Number	Shaft extension	Part number
N/A	-	Incremental 5-pin	735912	SC 50/15	738590	N/A	-
		Incremental 10-pin	919386				
		Differential 10-pin	919388				
		Mounting flange	781275				

BRx42-PGx42 PMDC planetary geared motor

12 - 48 V // 12 - 18 W // 8 - 698 rpm // 0.1 - 16.9 Nm

all dimensions in mm

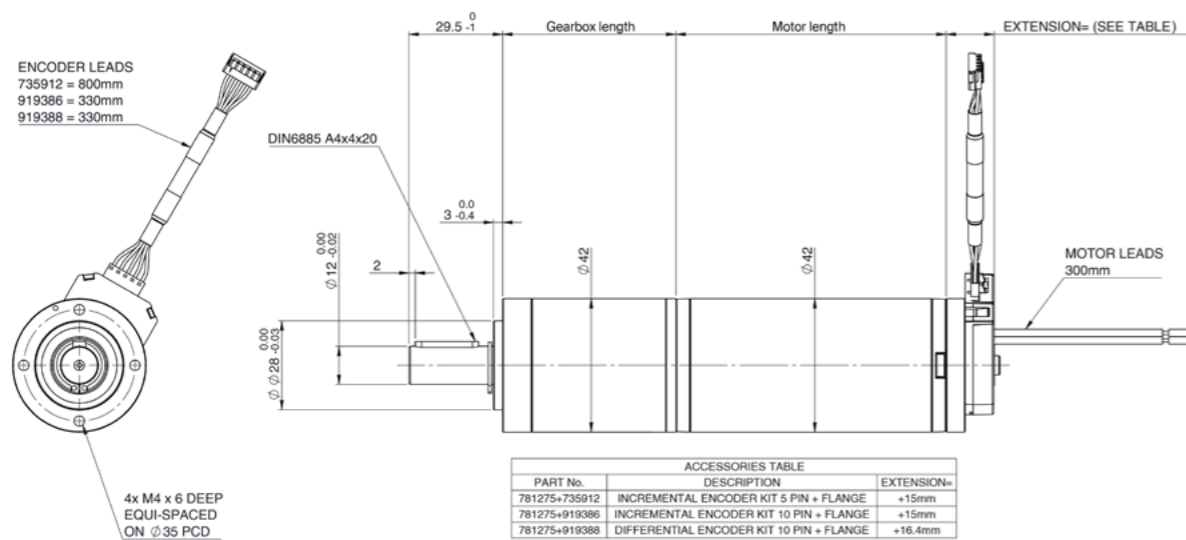

Combination data											
Motor		BRx42-25	BRx42-25	BRx42-25	BRx42-25	BRx42-25	BRx42-40	BRx42-40	BRx42-40	BRx42-40	BRx42-40
Voltage	V	12 - 24	12 - 24	12 - 24	12 - 24	12 - 24	12 - 48	12 - 48	12 - 48	12 - 48	12 - 48
Nominal motor power	W	12	12	12	12	12	18	18	18	18	18
Gearbox ratio	:1	4.3	19	66	150	353	4.3	19	66	150	353
Nominal speed	rpm	698	158	45	20	8	698	158	45	20	8
Continuous torque (S1)	Nm	0.1	0.6	1.8	3.6	8.6	0.2	0.9	2.7	5.5	11.3
Intermittent torque (S2 - 15 mins)	Nm	0.2	0.9	2.9	5.8	13.6	0.3	1.4	4.3	8.6	16.9

Motor data						
Part number		781076	781077	781079	781080	781081
Nominal power	W	12	12	18	18	18
Nominal voltage	V	12	24	12	24	28
Nominal speed	rpm	3000	3000	3000	3000	3000
Continuous torque (S1)	Nm	0.038	0.038	0.057	0.057	0.057
Intermittent torque (S2 - 15 minutes)	Nm	0.06	0.06	0.09	0.09	0.09
Weight	Kg	0.39	0.39	0.52	0.52	0.52
Stack length	mm	25	25	40	40	40
Motor length	mm	70	70	85	85	85

Gearbox data						
Part number		891037	891038	891039	891040	891041
Ratio	:1	4.3	19	66	150	353
Stage		1	2	3	4	4
Max. continuous torque (S1) ¹	Nm	2.3	5.6	11.3	11.3	11.3
Max. intermittent torque	Nm	3.4	8.5	16.9	16.9	16.9
Efficiency	%	90	81	72	64	64
Max. axial load (dynamic)	N	150	150	150	150	150
Max. radial load, 12mm from flange	N	120	240	360	360	360
Weight	Kg	0.26	0.36	0.46	0.56	0.56
Gearbox length	mm	37.3	51.8	66.3	80.8	80.8
Gear material		Steel	Steel	Steel	Steel	Steel

¹ S1 duty cycle based on 3000rpm input speed

Combination accessories							
Brake	Part number	Encoder	Part Number	Controller	Part Number	Shaft extension	Part number
N/A	-	Incremental 5-pin	735912	SC 50/15	738590	N/A	-
		Incremental 10-pin	919386				
		Differential 10-pin	919388				
		Mounting flange	781275				

PBL42-PGx42 PMDC planetary geared motor

24 - 48 V // 26 - 42 W // 11 - 930 rpm // 0.2 - 16.9 Nm

all dimensions in mm

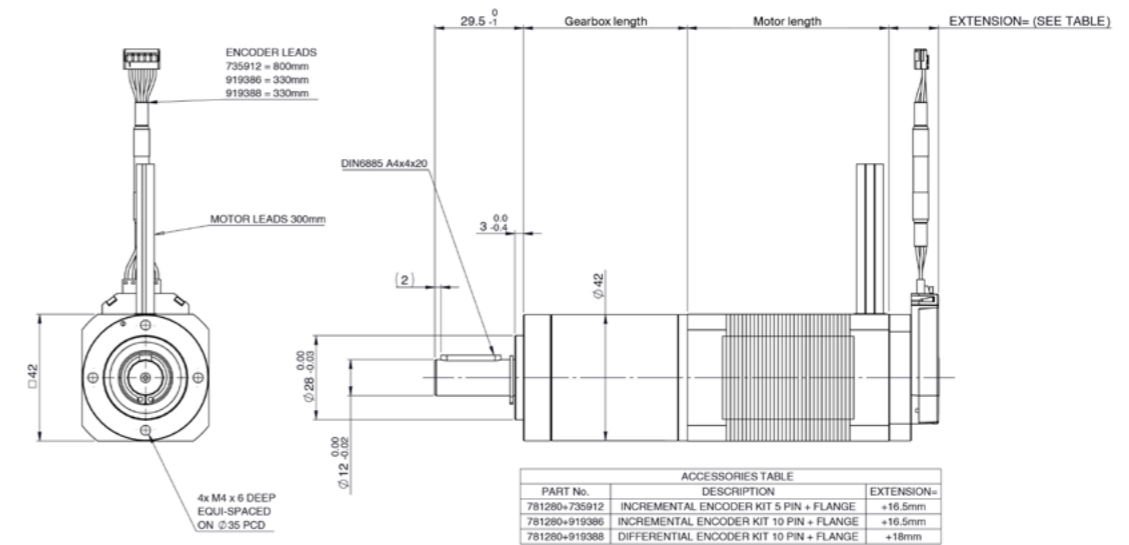

Combination data											
Motor		PBL42-15	PBL42-15	PBL42-15	PBL42-15	PBL42-15	PBL42-35	PBL42-35	PBL42-35	PBL42-35	PBL42-35
Voltage	V	12 - 24	12 - 24	12 - 24	12 - 24	12 - 24	12 - 24	12 - 24	12 - 24	12 - 24	12 - 24
Nominal motor power	W	26	26	26	26	26	42	42	42	42	42
Gearbox ratio	:1	4.3	19	66	150	353	4.3	19	66	150	353
Nominal speed	rpm	930	211	61	27	11	930	211	61	27	11
Continuous torque (S1)	Nm	0.2	1.0	3.0	6.0	11.3	0.4	1.5	4.8	9.6	11.3
Intermittent torque (S2 - 15 mins)	Nm	0.4	1.5	4.5	9.1	16.9	0.6	2.3	7.1	14.4	16.9

Motor data					Connection details			
Part number		776614	776615	776616	776617	Lead colour	Lead gauge	Function
Nominal power	W	26	26	42	42	Red	UL1569/26 AWG	VCC
Nominal voltage	V	24	48	24	48	Black	UL1569/26 AWG	GND
Nominal speed	rpm	4000	4000	4000	4000	Yellow	UL1569/26 AWG	Hall A
Continuous torque (S1)	Nm	0.063	0.063	0.10	0.10	Green	UL1569/26 AWG	Hall B
Intermittent torque (S2 - 15 minutes)	Nm	0.095	0.095	0.15	0.15	Blue	UL1569/26 AWG	Hall C
Weight	Kg	0.30	0.30	0.45	0.45	Yellow	UL1569/20 AWG	Phase U
Stack length	mm	15	15	35	35	Green	UL1569/20 AWG	Phase V
Motor length	mm	47	47	67	67	Blue	UL1569/20 AWG	Phase W

Gearbox data						
Part number		891037	891038	891039	891040	891041
Ratio	:1	4.3	19	66	150	353
Stage		1	2	3	4	4
Max. continuous torque (S1) ¹	Nm	2.3	5.6	11.3	11.3	11.3
Max. intermittent torque	Nm	3.4	8.5	16.9	16.9	16.9
Efficiency	%	90	81	72	64	64
Max. axial load (dynamic)	N	150	150	150	150	150
Max. radial load, 12mm from flange	N	120	240	360	360	360
Weight	Kg	0.26	0.36	0.46	0.56	0.56
Gearbox length	mm	37.3	51.8	66.3	80.8	80.8
Gear material		Steel	Steel	Steel	Steel	Steel

¹ S1 duty cycle based on 3000rpm input speed

Combination accessories							
Brake	Part number	Encoder	Part Number	Controller	Part Number	Shaft extension	Part number
N/A	-	Incremental 5-pin	735912	SC 50/15	738590	N/A	-
		Incremental 10-pin	919386				
		Differential 10-pin	919388				
		Mounting flange	781280				

GB28 combinations

Supplied as standard with a hollow shaft, the GB28 right-angle gearbox can be integrated with our PBL42, PBL60, and BRx63 modular motors.

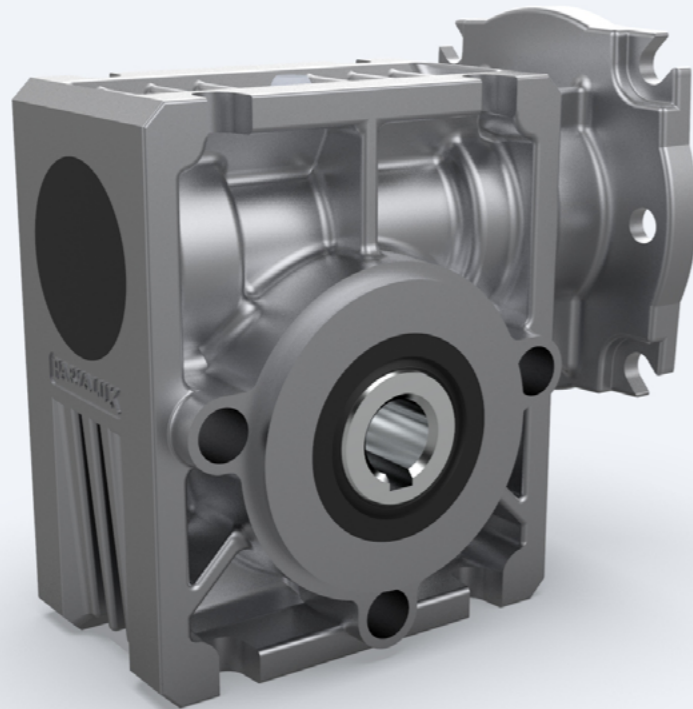

PBL42-GB28 BLDC right-angle geared motor

24 - 48 V // 26 - 42 W // 67 - 267 rpm // 0.7 - 4.1 Nm

all dimensions in mm

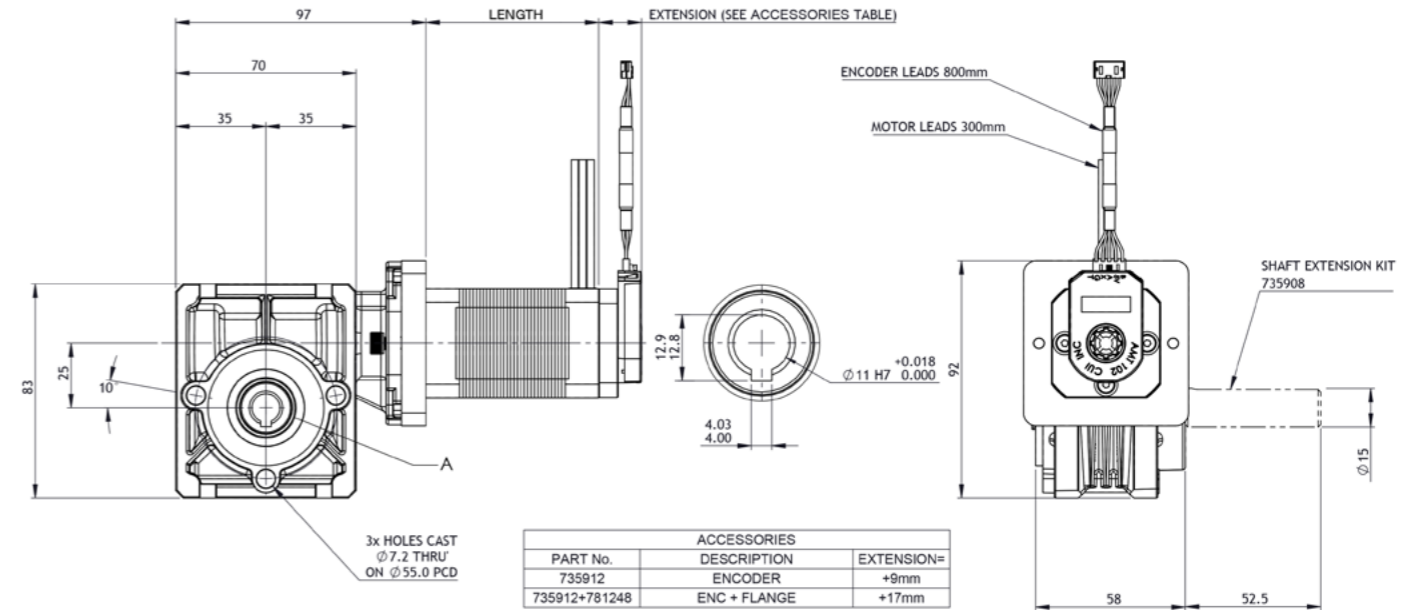

Combination data							
Motor		PBL42-15	PBL42-15	PBL42-15	PBL42-35	PBL42-35	PBL42-35
Voltage	V	24 - 48	24 - 48	24 - 48	24 - 48	24 - 48	24 - 48
Nominal motor power	W	26	26	26	42	42	42
Gearbox ratio	:1	15	30	60	15	30	60
Nominal speed	rpm	267	133	67	267	133	67
Nominal torque ¹	Nm	0.7	1.2	1.7	1.1	2.0	2.7
Intermittent torque (S2 - 15 mins)	Nm	1.1	1.9	2.6	1.7	2.9	4.1

Motor data					Connection details			
Part number		776614	776615	776616	776617	Lead colour	Lead gauge	Function
Nominal power	W	26	26	42	42	Red	UL1569/26 AWG	VCC
Nominal voltage	V	24	48	24	48	Black	UL1569/26 AWG	GND
Nominal speed	rpm	4000	4000	4000	4000	Yellow	UL1569/26 AWG	Hall A
Continuous torque (S1)	Nm	0.063	0.063	0.10	0.10	Green	UL1569/26 AWG	Hall B
Intermittent torque (S2 - 15 minutes)	Nm	0.095	0.095	0.15	0.15	Blue	UL1569/26 AWG	Hall C
Weight	Kg	0.30	0.30	0.45	0.45	Yellow	UL1569/20 AWG	Phase U
Stack length	mm	15	15	35	35	Green	UL1569/20 AWG	Phase V
Length	mm	47	47	67	67	Blue	UL1569/20 AWG	Phase W

Gearbox data				
Part number		735904	735906	735907
Ratio	:1	15	30	60
Max. continuous torque (S1) ²	Nm	5.0	5.0	5.0
Max. intermittent torque	Nm	8.0	8.0	8.0
Efficiency	%	75	65	45
Max. axial load (dynamic)	N	300	300	300
Max. radial load, 12mm from flange	N	400	400	400
Weight	Kg	0.83	0.83	0.83
Gear material		Bronze	Bronze	Bronze

² S1 duty cycle based on 3000rpm input speed

Combination accessories							
Brake	Part number	Encoder	Part Number	Controller	Part Number	Shaft extension	Part number
N/A	-	Incremental 5-pin	735912	SC 50/15	738590	GB28 shaft kit	735908
		Incremental 10-pin	919386				
		Differential 10-pin	919388				
		Mounting flange	781280				

BRx63-GB28

PMDC right-angle geared motor

12 - 48 V // 47 - 85 W // 42 - 200 rpm // 2.0 - 8.0 Nm

all dimensions in mm

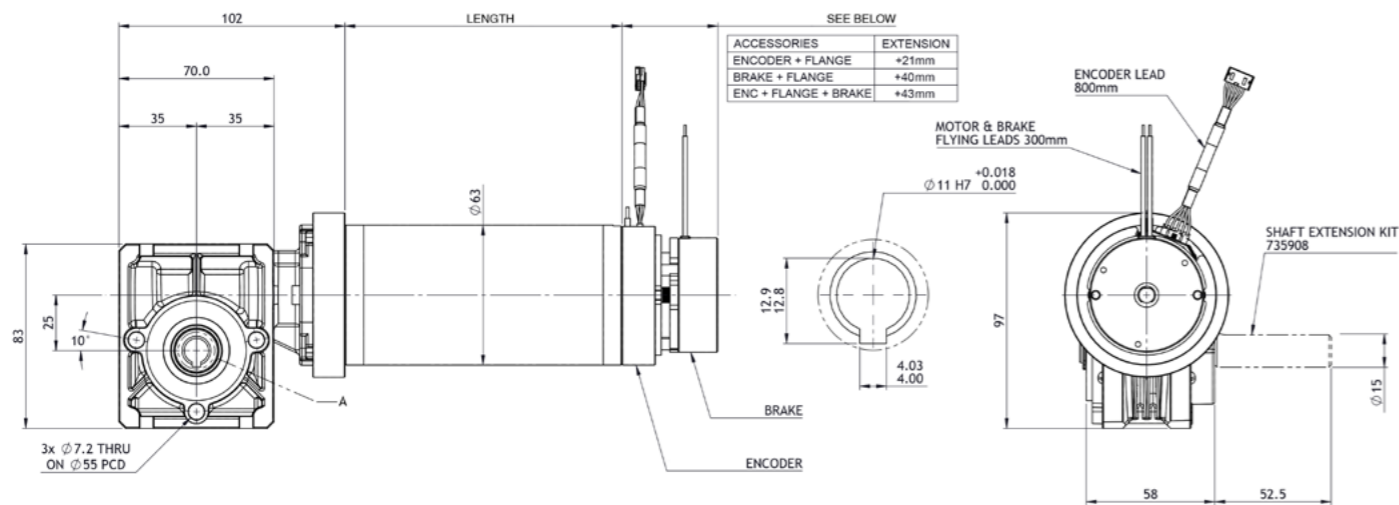

Combination data

Motor	BRx63-25	BRx63-25	BRx63-25	BRx63-55	BRx63-55	BRx63-55
Voltage	V	12 - 48	12 - 48	12 - 48	12 - 48	12 - 48
Nominal motor power	W	47 - 57	47 - 57	47 - 57	79 - 85	79 - 85
Gearbox ratio	:1	15	30	60	15	30
Nominal speed	rpm	167 - 200	83 - 100	42 - 50	187 - 200	93 - 100
Nominal torque ¹	Nm	2.0	3.5	4.9	3.0	5.0
Intermittent torque (S2 - 15 mins)	Nm	3.4	5.9	8.0	5.1	8.0

Motor data

Part number	781083	781084	781085	781088	781089	781090
Nominal power	W	47	57	57	79	85
Nominal voltage	V	12	24	48	12	24
Nominal speed	rpm	2500	3000	3000	2800	3000
Continuous torque (S1)	Nm	0.18	0.18	0.18	0.27	0.27
Intermittent torque (S2 - 15 minutes)	Nm	0.30	0.30	0.30	0.45	0.45
Weight	Kg	0.85	0.85	0.85	1.16	1.16
Stack length	mm	25	25	25	55	55
Length	mm	95	95	95	125	125

Gearbox data

Part number	735904	735906	735907
Ratio	:1	15	30
Max. continuous torque (S1) ²	Nm	5.0	5.0
Max. intermittent torque	Nm	8.0	8.0
Efficiency	%	75	65
Max. axial load (dynamic)	N	300	300
Max. radial load, 12mm from flange	N	400	400
Weight	Kg	0.83	0.83
Gear material	Bronze	Bronze	Bronze

² S1 duty cycle based on 3000rpm input speed

Combination accessories

Brake	Part number	Encoder	Part Number	Controller	Part Number	Shaft extension	Part number
1.5 Nm brake	735914	Incremental 5-pin	735912	SC 50/15	738590	GB28 shaft kit	735908
Mounting flange	781276	Incremental 10-pin	919386				
		Differential 10-pin	919388				
		Mounting flange	781276				

PBL60-GB28

BLDC right-angle geared motor

24 - 48 V // 104 - 157 W // 50 - 200 rpm // 3.7 - 8.0 Nm

all dimensions in mm

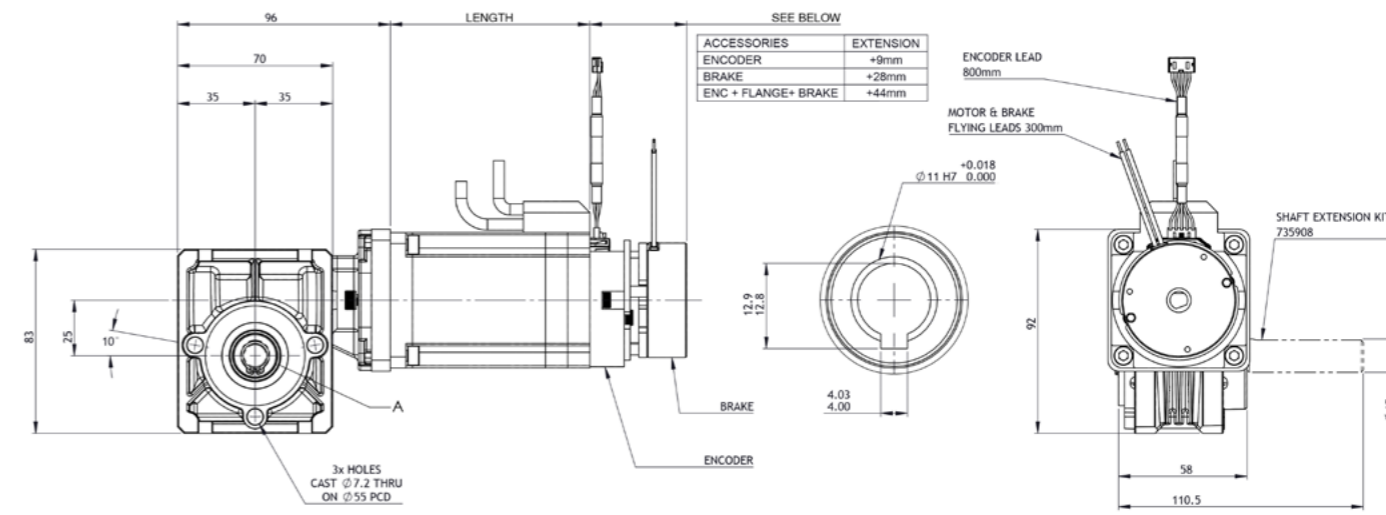

Combination data

Motor	PBL60-50	PBL60-50	PBL60-50	PBL60-70	PBL60-70	PBL60-70
Voltage	V	24 - 48	24 - 48	24 - 48	24 - 48	24 - 48
Nominal motor power	W	104	104	104	157	157
Gearbox ratio	:1	15	30	60	15	30
Nominal speed	rpm	200	100	50	200	100
Nominal torque ¹	Nm	3.7	5.0	5.0	5.0	5.0
Intermittent torque (S2 - 15 mins)	Nm	6.5	8.0	8.0	8.0	8.0

Motor data

Part number	776618	776619	776620	776621	Connection details		
Nominal power	W	104	104	157	Lead colour	Lead gauge	Function
Nominal voltage	V	24	48	24	Red	UL1569/26 AWG	VCC
Nominal speed	rpm	3000	3000	3000	Black	UL1569/26 AWG	GND
Continuous torque (S1)	Nm	0.33	0.33	0.50	Blue	UL1569/26 AWG	Hall A
Intermittent torque (S2 - 15 minutes)	Nm	0.58	0.58	0.88	Green	UL1569/26 AWG	Hall B
Weight	Kg	1.20	1.20	1.60	White	UL1569/26 AWG	Hall C
Stack length	mm	50	50	70	Red	UL3266/18 AWG	Phase U
Length	mm	90	90	110	Yellow	UL3266/18 AWG	Phase V
					Black	UL3266/18 AWG	Phase W

Gearbox data

Part number	735904	735906	735907
Ratio	:1	15	30
Max. continuous torque (S1) ²	Nm	5.0	5.0
Max. intermittent torque	Nm	8.0	8.0
Efficiency	%	75	65
Max. axial load (dynamic)	N	300	300
Max. radial load, 12mm from flange	N	400	400
Weight	Kg	0.83	0.83
Gear material	Bronze	Bronze	Bronze

² S1 duty cycle based on 3000rpm input speed

Combination accessories

Brake	Part number	Encoder	Part Number	Controller	Part Number	Shaft extension	Part number
1.5 Nm brake	735914	Incremental 5-pin	735912	SC 50/15	738590	GB28 shaft kit	735908
Mounting flange	781281	Incremental 10-pin	919386				
		Differential 10-pin	919388				

BRx63-GB80

PMDC right-angle geared motor

all dimensions in mm

12 - 48 V // 47 - 85 W // 42 - 200 rpm // 2.1 - 10.0 Nm

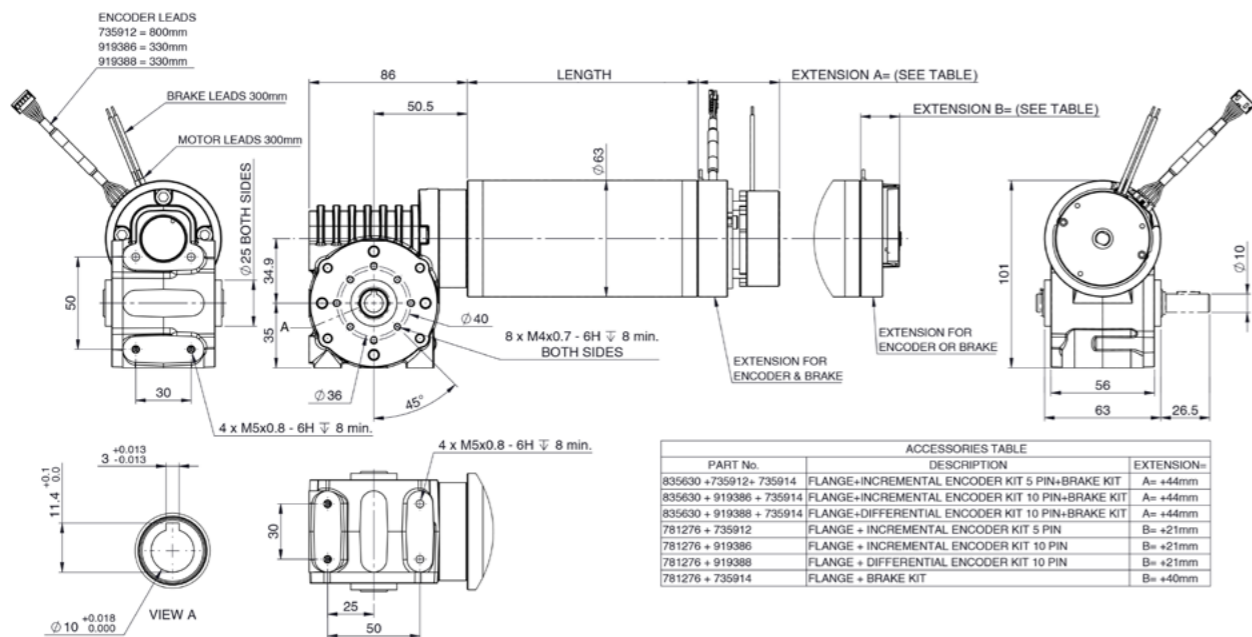

Combination data

Motor	BRx63-25	BRx63-25	BRx63-25	BRx63-55	BRx63-55	BRx63-55
Voltage	V	12 - 48	12 - 48	12 - 48	12 - 48	12 - 48
Nominal motor power	W	47 - 57	47 - 57	47 - 57	79 - 85	79 - 85
Gearbox ratio	:1	15	30	60	15	30
Nominal speed	rpm	167 - 200	83 - 100	42 - 50	187 - 200	93 - 100
Nominal torque ¹	Nm	2.1	3.8	5.8	3.1	5.7
Intermittent torque (S2 - 15 mins)	Nm	3.5	6.3	9.7	5.2	10.0

Motor data

Part number	781083	781084	781085	781088	781089	781090
Nominal power	W	47	57	57	79	85
Nominal voltage	V	12	24	48	12	24
Nominal speed	rpm	2500	3000	3000	2800	3000
Continuous torque (S1)	Nm	0.18	0.18	0.18	0.27	0.27
Intermittent torque (S2 - 15 minutes)	Nm	0.30	0.30	0.30	0.45	0.45
Weight	Kg	0.85	0.85	0.85	1.16	1.16
Stack length	mm	25	25	25	55	55
Length	mm	95	95	95	125	125

Gearbox data

Part number	888018	888020	888021
Ratio	:1	15	30
Max. continuous torque (S1) ²	Nm	8.0	8.0
Max. intermittent torque	Nm	13.0	13.0
Efficiency	%	77	70
Max. axial load (dynamic)	N	300	300
Max. radial load, 12mm from flange	N	350	350
Weight	Kg	0.7	0.7
Gear material	Composite	Composite	Composite

² S1 duty cycle based on 3000rpm input speed

Combination accessories

Brake	Part number	Encoder	Part Number	Controller	Part Number	Shaft extension	Part number
1.5 Nm brake	735914	Incremental 5-pin	735912	SC 50/15	738590	GB80 shaft kit	860809
Mounting flange	781276	Incremental 10-pin	919386				
		Differential 10-pin	919388				
		Mounting flange	781276				

PBL60-GB80

BLDC right-angle geared motor

all dimensions in mm

24 - 48 V // 104 - 157 W // 50 - 200 rpm // 3.8 - 13.0 Nm

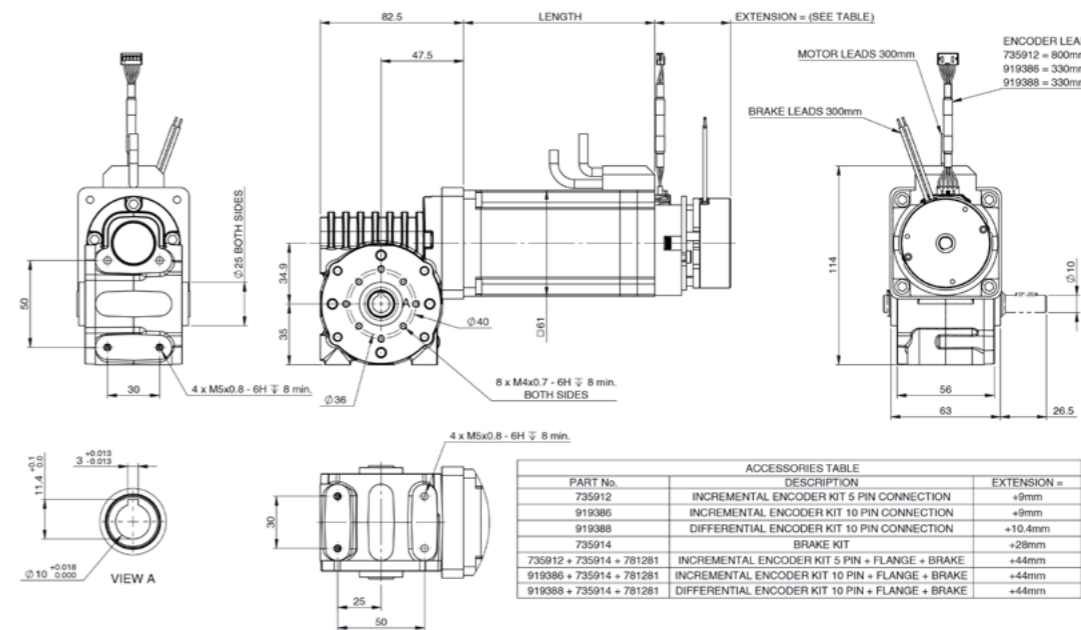

Combination data

Motor	PBL60-50	PBL60-50	PBL60-50	PBL60-70	PBL60-70	PBL60-70
Voltage	V	24 - 48	24 - 48	24 - 48	24 - 48	24 - 48
Nominal motor power	W	104	104	104	157	157
Gearbox ratio	:1	15	30	60	15	30
Nominal speed	rpm	200	100	50	200	100
Nominal torque ¹	Nm	3.8	6.9	6.0	5.8	8.0
Intermittent torque (S2 - 15 mins)	Nm	6.7	12.2	10.0	10.2	13.0

Motor data

Part number	776618	776619	776620	776621	Connection details	
Nominal power	W	104	104	157	Lead colour	Function
Nominal voltage	V	24	48	24	48	Lead gauge
Nominal speed	rpm	3000	3000	3000	3000	UL1569/26 AWG
Continuous torque (S1)	Nm	0.33	0.33	0.50	0.50	VCC
Intermittent torque (S2 - 15 minutes)	Nm	0.58	0.58	0.88	0.88	GND
Weight	Kg	1.20	1.20	1.60	1.60	Hall A
Stack length	mm	50	50	70	70	Hall B
Length	mm	90	90	110	110	Hall C
						Phase U
						Phase V
						Phase W

Gearbox data

Part number	888018	888020	888021
Ratio	:1	15	30
Max. continuous torque (S1) ²	Nm	8.0	8.0
Max. intermittent torque	Nm	13.0	13.0
Efficiency	%	77	70
Max. axial load (dynamic)	N	300	300
Max. radial load, 12mm from flange	N	350	350
Weight	Kg	0.7	0.7
Gear material	Composite	Composite	Composite

² S1 duty cycle based on 3000rpm input speed

Combination accessories

Brake	Part number	Encoder	Part Number	Controller	Part Number	Shaft extension	Part number
1.5 Nm brake	735914	Incremental 5-pin	735912	SC 50/15	738590	GB80 shaft kit	860809
Mounting flange	781281	Incremental 10-pin	919386				
		Differential 10-pin	919388				

GB12 combinations

Supplied as standard with a hollow shaft, the GB12 right-angle gearbox can be integrated with our PBL60, PBL70, PBL86, BRx70, and BRx90 modular motors.

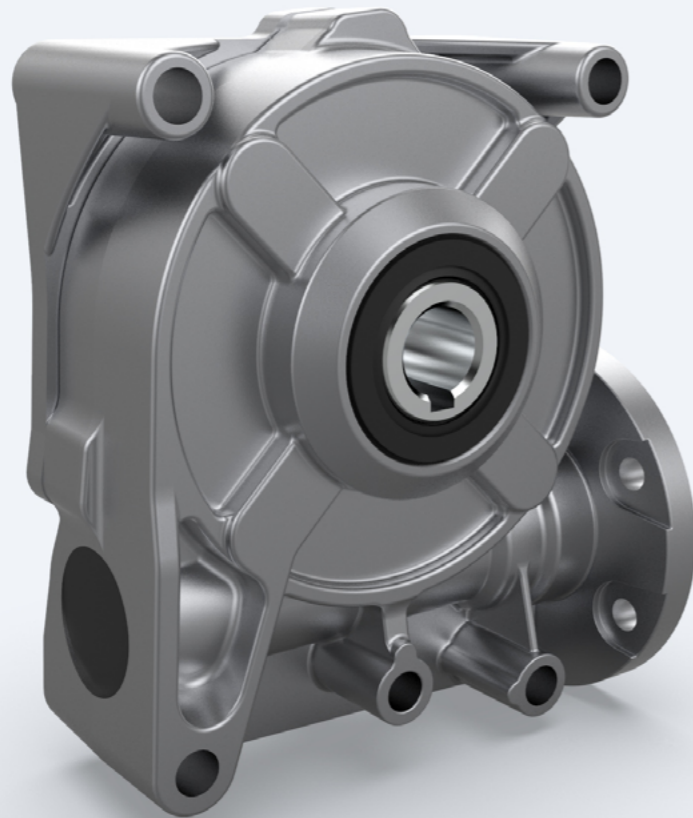

PBL60-GB12 BLDC right-angle geared motor

24 - 48 V // 104 - 157 W // 50 - 200 rpm // 3.7 - 26.4 Nm

all dimensions in mm

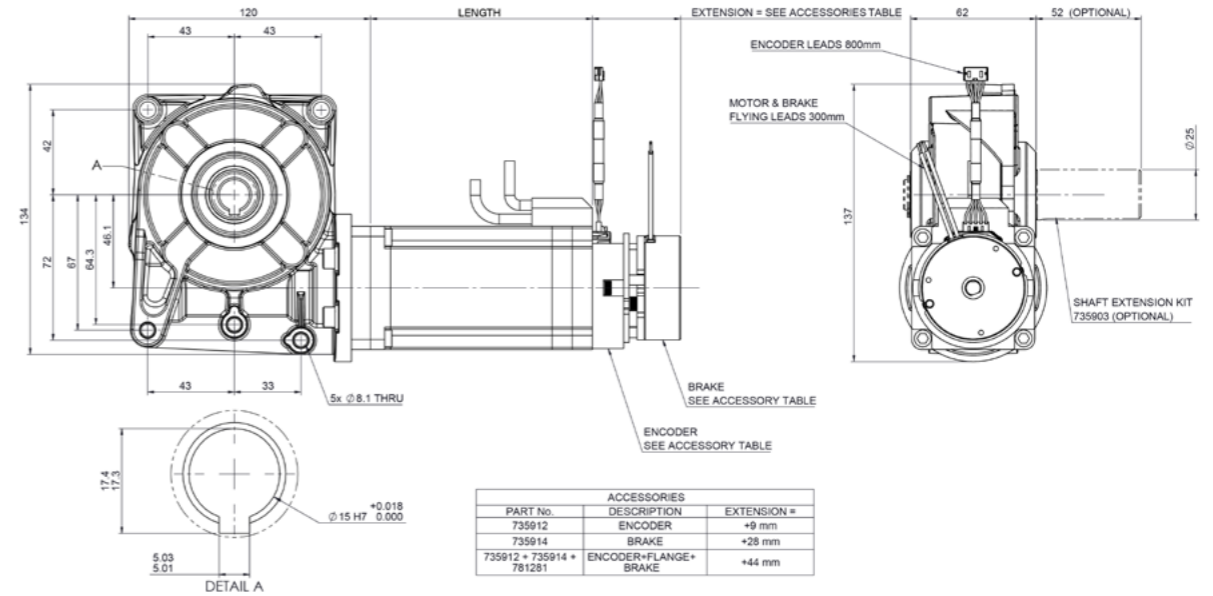

Combination data							
Motor		PBL60-50	PBL60-50	PBL60-50	PBL60-70	PBL60-70	PBL60-70
Voltage	V	24 - 48	24 - 48	24 - 48	24 - 48	24 - 48	24 - 48
Nominal motor power	W	104	104	104	157	157	157
Gearbox ratio	:1	15	30	60	15	30	60
Nominal speed	rpm	200	100	50	200	100	50
Nominal torque ¹	Nm	3.7	6.4	9.9	5.6	9.8	15.0
Intermittent torque (S2 - 15 mins)	Nm	6.5	11.3	17.4	9.9	17.2	26.4

Motor data					Connection details			
Part number		776618	776619	776620	776621	Lead colour	Lead gauge	Function
Nominal power	W	104	104	157	157	Red	UL1569/26 AWG	VCC
Nominal voltage	V	24	48	24	48	Black	UL1569/26 AWG	GND
Nominal speed	rpm	3000	3000	3000	3000	Blue	UL1569/26 AWG	Hall A
Continuous torque (S1)	Nm	0.33	0.33	0.50	0.50	Green	UL1569/26 AWG	Hall B
Intermittent torque (S2 - 15 minutes)	Nm	0.58	0.58	0.88	0.88	White	UL1569/26 AWG	Hall C
Weight	Kg	1.20	1.20	1.60	1.60	Red	UL3266/18 AWG	Phase U
Stack length	mm	50	50	70	70	Yellow	UL3266/18 AWG	Phase V
Length	mm	90	90	110	110	Black	UL3266/18 AWG	Phase W

Gearbox data				
Part number		735900	735901	735902
Ratio	:1	15	30	60
Max. continuous torque (S1) ²	Nm	30.0	30.0	30.0
Max. intermittent torque	Nm	48.0	48.0	48.0
Efficiency	%	75	65	50
Max. axial load (dynamic)	N	600	600	600
Max. radial load, 12mm from flange	N	800	800	800
Weight	Kg	1.5	1.5	1.5
Gear material		Bronze	Bronze	Bronze

² S1 duty cycle based on 3000rpm input speed

Combination accessories							
Brake	Part number	Encoder	Part Number	Controller	Part Number	Shaft extension	Part number
1.5 Nm brake	735914	Incremental 5-pin	735912	SC 50/15	738590	GB12 shaft kit	735903
Mounting flange	781281	Incremental 10-pin	919386				
		Differential 10-pin	919388				

BRx70-GB12

PMDC right-angle geared motor

12 - 48 V // 79 - 157 W // 50 - 200 rpm // 2.8 - 26.4 Nm

all dimensions in mm

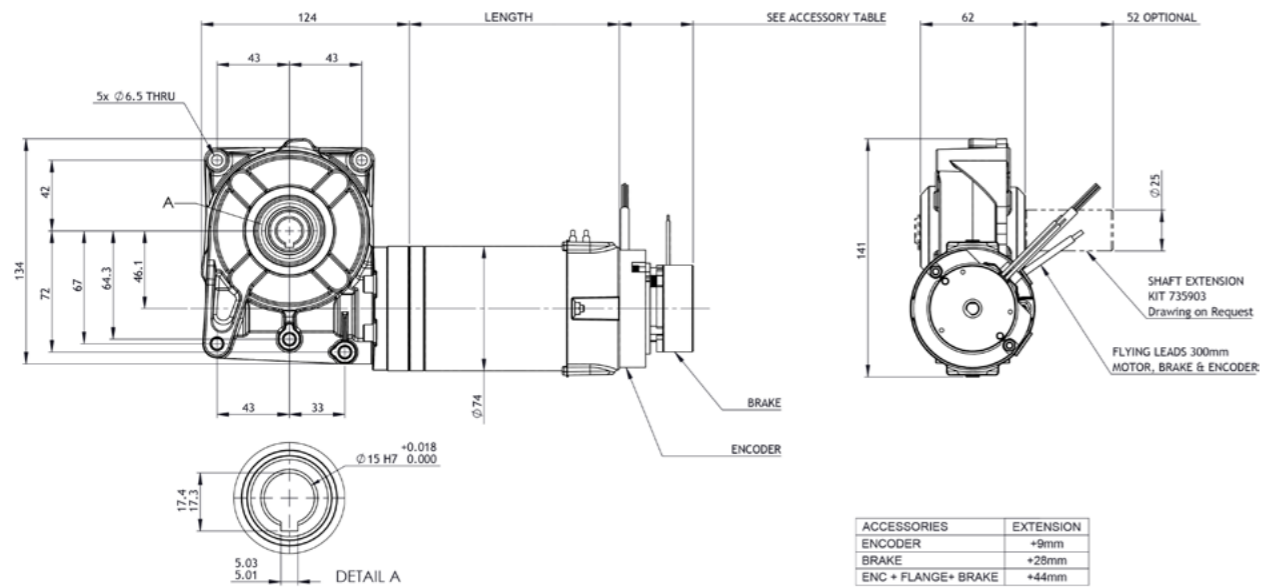

Combination data

Motor		BRx70-40	BRx70-40	BRx70-40	BRx70-60	BRx70-60	BRx70-60
Voltage	V	12 - 48	12 - 48	12 - 48	12 - 48	12 - 48	12 - 48
Nominal motor power	W	79	79	79	157	157	157
Gearbox ratio	:1	15	30	60	15	30	60
Nominal speed	rpm	200	100	50	200	100	50
Nominal torque ¹	Nm	2.8	4.9	7.5	5.6	9.8	15.0
Intermittent torque (S2 - 15 mins)	Nm	4.7	8.2	12.6	9.9	17.2	26.4

Motor data

Part number		781092	781093	781094	781095	781096	781097
Nominal power	W	79	79	79	157	157	157
Nominal voltage	V	12	24	48	12	24	48
Nominal speed	rpm	3000	3000	3000	3000	3000	3000
Continuous torque (S1)	Nm	0.25	0.25	0.25	0.50	0.50	0.50
Intermittent torque (S2 - 15 minutes)	Nm	0.42	0.42	0.42	0.88	0.88	0.88
Weight	Kg	1.85	1.85	1.85	2.25	2.25	2.25
Stack length	mm	40	40	40	60	60	60
Length	mm	125	125	125	146	146	146

Gearbox data

Part number		735900	735901	735902
Ratio	:1	15	30	60
Max. continuous torque (S1) ²	Nm	30.0	30.0	30.0
Max. intermittent torque	Nm	48.0	48.0	48.0
Efficiency	%	75	65	50
Max. axial load (dynamic)	N	600	600	600
Max. radial load, 12mm from flange	N	800	800	800
Weight	Kg	1.5	1.5	1.5
Gear material		Bronze	Bronze	Bronze

² S1 duty cycle based on 3000rpm input speed

Combination accessories

Brake	Part number	Encoder	Part Number	Controller	Part Number	Shaft extension	Part number
1.5 Nm brake	735914	Incremental 5-pin	735912	SC 50/15	738590	GB12 shaft kit	735903
Mounting flange	781277	Incremental 10-pin	919386				
		Differential 10-pin	919388				

PBL70-GB12

BLDC right-angle geared motor

48 V // 363 - 415 W // 75 - 300 rpm // 8.7 - 46.2 Nm

all dimensions in mm

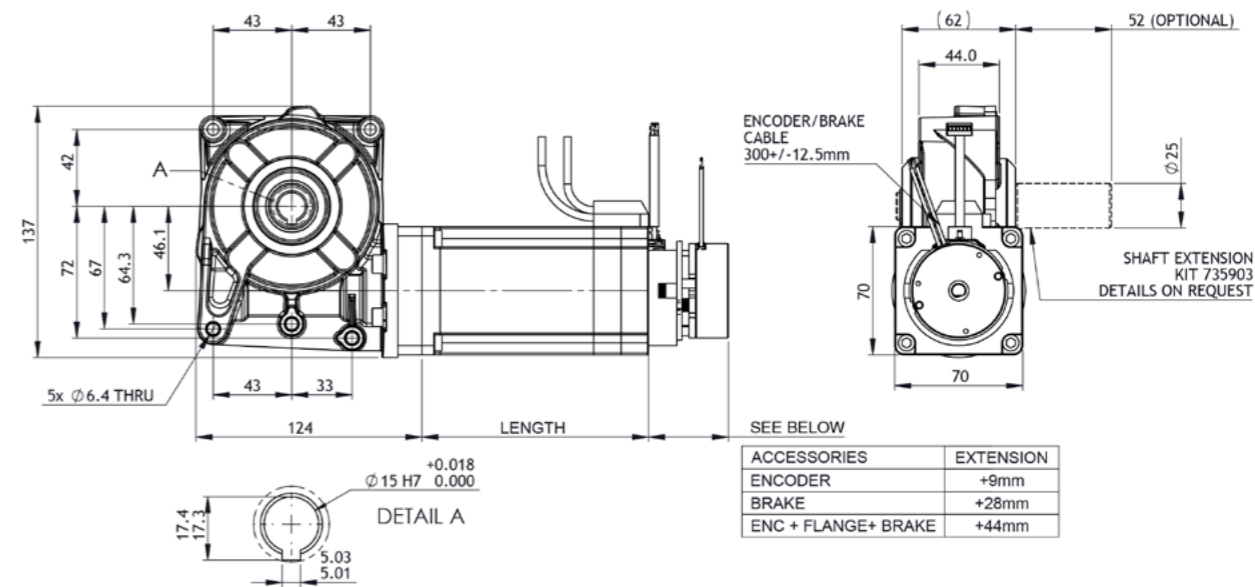

Combination data

Motor		PBL70-70	PBL70-70	PBL70-70	PBL70-80	PBL70-80	PBL70-80
Voltage	V	48	48	48	48	48	48
Nominal motor power	W	363	363	363	415	415	415
Gearbox ratio	:1	15	30	60	15	30	60
Nominal speed	rpm	300	150	75	300	150	75
Nominal torque ¹	Nm	8.7	15.0	23.1	9.9	17.2	26.4
Intermittent torque (S2 - 15 mins)	Nm	15.2	26.3	40.5	17.3	30.0	46.2

Motor data

Part number		776622	776623	Connection details		
Nominal power	W	363	415	Lead colour	Lead gauge	Function
Nominal voltage	V	48	48	Red	UL1569/26 AWG	VCC
Nominal speed	rpm	4500	4500	Black	UL1569/26 AWG	GND
Continuous torque (S1)	Nm	0.77	0.88	Blue	UL1569/26 AWG	Hall A
Intermittent torque (S2 - 15 minutes)	Nm	1.35	1.54	Green	UL1569/26 AWG	Hall B
Weight	Kg	2.20	2.60	White	UL1569/26 AWG	Hall C
Stack length	mm	40	60	Red	UL3266/16 AWG	Phase U
Length	mm	114	124	Yellow	UL3266/16 AWG	Phase V
				Black	UL3266/16 AWG	Phase W

Gearbox data

Part number		735900	735901	735902
Ratio	:1	15	30	60
Max. continuous torque (S1) ²	Nm	30.0	30.0	30.0
Max. intermittent torque	Nm	48.0	48.0	48.0
Efficiency	%	75	65	50
Max. axial load (dynamic)	N	600	600	600
Max. radial load, 12mm from flange	N	800	800	800
Weight	Kg	1.5	1.5	1.5
Gear material		Bronze	Bronze	Bronze

² S1 duty cycle based on 3000rpm input speed

Combination accessories

Brake	Part number	Encoder	Part Number	Controller	Part Number	Shaft extension	Part number
1.5 Nm brake	735914	Incremental 5-pin	735912	SC 50/15	738590	GB12 shaft kit	735903
Mounting flange	781281	Incremental 10-pin	919386				
		Differential 10-pin	919388				

BRx90-GB12

PMDC right-angle geared motor

12 - 48 V // 157 - 283 W // 42 - 200 rpm // 5.6 - 45.0 Nm

all dimensions in mm

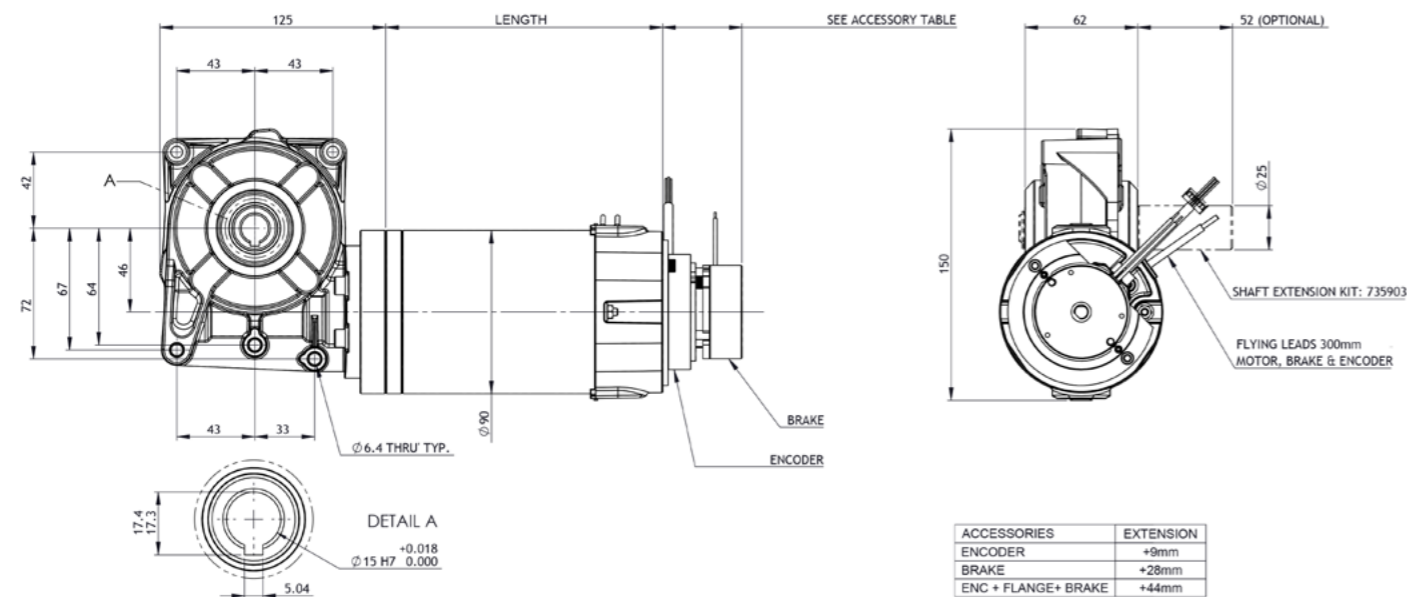

Combination data

Motor	BRx90-50	BRx90-50	BRx90-50	BRx90-75	BRx90-75	BRx90-75
Voltage	V 12 - 48	12 - 48	12 - 48	12 - 48	12 - 48	12 - 48
Nominal motor power	W 157 - 210	157 - 210	157 - 210	236 - 283	236 - 283	236 - 283
Gearbox ratio	:1 15	30	60	15	30	60
Nominal speed	rpm 200	100	50	167 - 200	83 - 100	42 - 50
Nominal torque ¹	Nm 5.6 - 7.5	9.8 - 13.1	15.0 - 20.1	10.1	17.6	27.0
Intermittent torque (S2 - 15 mins)	Nm 13.2	22.8	35.1	16.9	29.3	45.0

Motor data

Part number	781102	781103	781104	781106	781107	781108
Nominal power	W 157	210	210	236	283	283
Nominal voltage	V 12	24	48	12	24	48
Nominal speed	rpm 3000	3000	3000	2500	3000	3000
Continuous torque (S1)	Nm 0.50	0.67	0.67	0.90	0.90	0.90
Intermittent torque (S2 - 15 minutes)	Nm 1.17	1.17	1.17	1.50	1.50	1.50
Weight	Kg 3.60	3.60	3.60	4.00	4.00	4.00
Stack length	mm 50	50	50	75	75	75
Length	mm 153	153	153	183	183	183

Gearbox data

Part number	735900	735901	735902
Ratio	:1 15	30	60
Max. continuous torque (S1) ²	Nm 30.0	30.0	30.0
Max. intermittent torque	Nm 48.0	48.0	48.0
Efficiency	% 75	65	50
Max. axial load (dynamic)	N 600	600	600
Max. radial load, 12mm from flange	N 800	800	800
Weight	Kg 1.5	1.5	1.5
Gear material	Bronze	Bronze	Bronze

² S1 duty cycle based on 3000rpm input speed

Combination accessories

Brake	Part number	Encoder	Part Number	Controller	Part Number	Shaft extension	Part number
1.5 Nm brake	735914	Incremental 5-pin	735912	SC 50/15	738590	GB12 shaft kit	735903
Mounting flange	781279	Incremental 10-pin	919386				
		Differential 10-pin	919388				

PBL86-GB12

BLDC right-angle geared motor

48 V // 419 - 586 W // 67 - 267 rpm // 11.3 - 48.0 Nm

all dimensions in mm

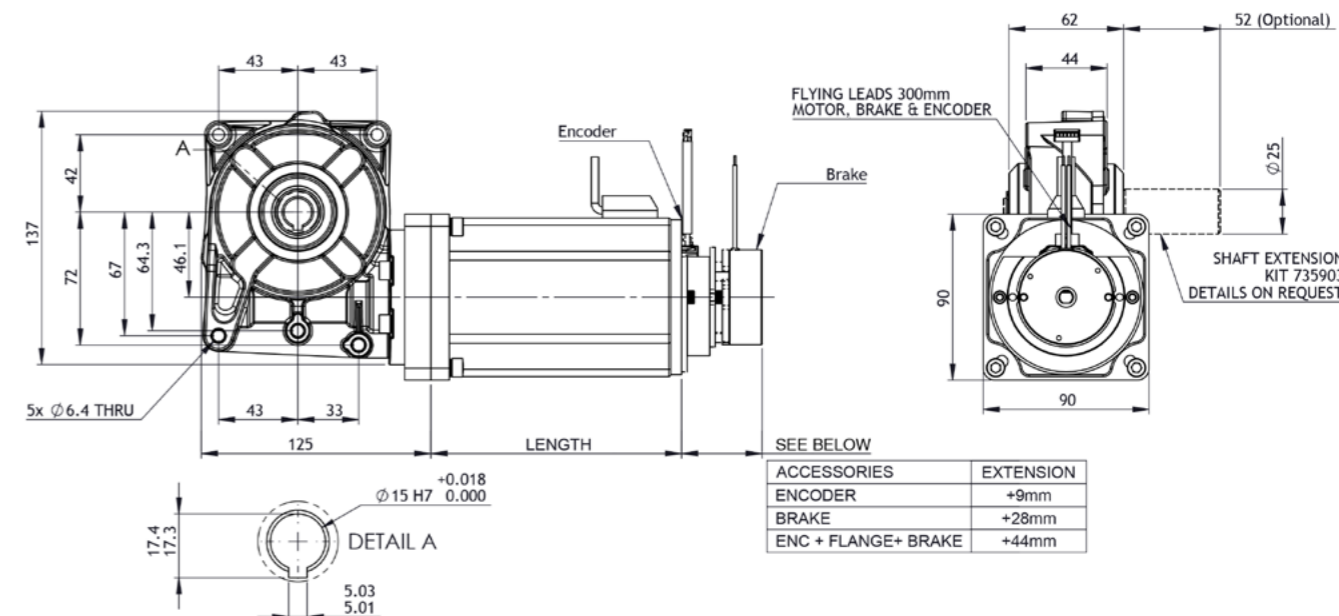

Combination data

Motor	PBL86-55	PBL86-55	PBL86-55	PBL86-80	PBL86-80	PBL86-80
Voltage	V 48	48	48	48	48	48
Nominal motor power	W 419	419	419	586	586	586
Gearbox ratio	:1 15	30	60	15	30	60
Nominal speed	rpm 267	133	67	267	133	67
Nominal torque ¹	Nm 11.3	19.5	30.0	15.8	27.3	30.0
Intermittent torque (S2 - 15 mins)	Nm 19.7	34.1	48.0	27.6	47.8	48.0

Motor data

Part number	776624	776625
Nominal power	W 419	586
Nominal voltage	V 48	48
Nominal speed	rpm 4000	4000
Continuous torque (S1)	Nm 1.00	1.40
Intermittent torque (S2 - 15 minutes)	Nm 1.75	2.45
Weight	Kg 3.20	4.20
Stack length	mm 55	80
Length	mm 111	136

Connection details

Lead colour	Lead gauge	Function
Red	UL1569/26 AWG	VCC
Black	UL1569/26 AWG	GND
Blue	UL1569/26 AWG	Hall A
Green	UL1569/26 AWG	Hall B
White	UL1569/26 AWG	Hall C
Red	UL1569/14 AWG	Phase U
Yellow	UL1569/14 AWG	Phase V
Black	UL1569/14 AWG	Phase W

Gearbox data

Part number	735900	735901	735902
Ratio	:1 15	30	60
Max. continuous torque (S1) ²	Nm 30.0	30.0	30.0
Max. intermittent torque	Nm 48.0	48.0	48.0
Efficiency	% 75	65	50
Max. axial load (dynamic)	N 600	600	600
Max. radial load, 12mm from flange	N 800	800	800
Weight	Kg 1.5	1.5	1.5
Gear material	Bronze	Bronze	Bronze

² S1 duty cycle based on 3000rpm input speed

Combination accessories

Brake	Part number	Encoder	Part Number	Controller	Part Number	Shaft extension	Part number
1.5 Nm brake	735914	Incremental 5-pin	735912	SC 50/15	738590	GB12 shaft kit	735903
Mounting flange	781284	Incremental 10-pin	919386				
		Differential 10-pin	919388				

GB9 combinations

Supplied as standard with a hollow shaft, the GB9 right-angle gearbox can be integrated with our PBL86 and BRx90 modular motors.

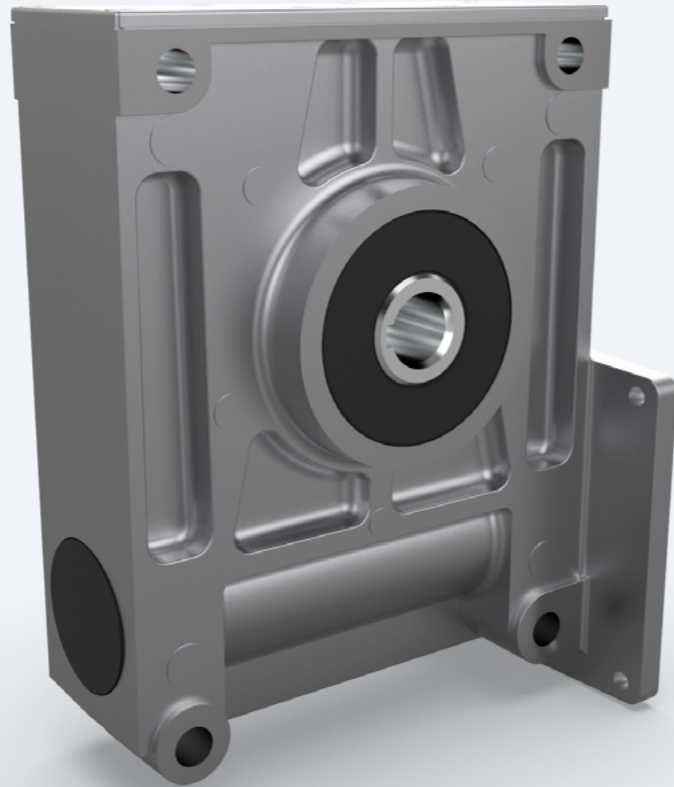

BRx90-GB9 PMDC right-angle geared motor

12 - 48 V // 157 - 283 W // 42 - 200 rpm // 6.4 - 58.5 Nm

all dimensions in mm

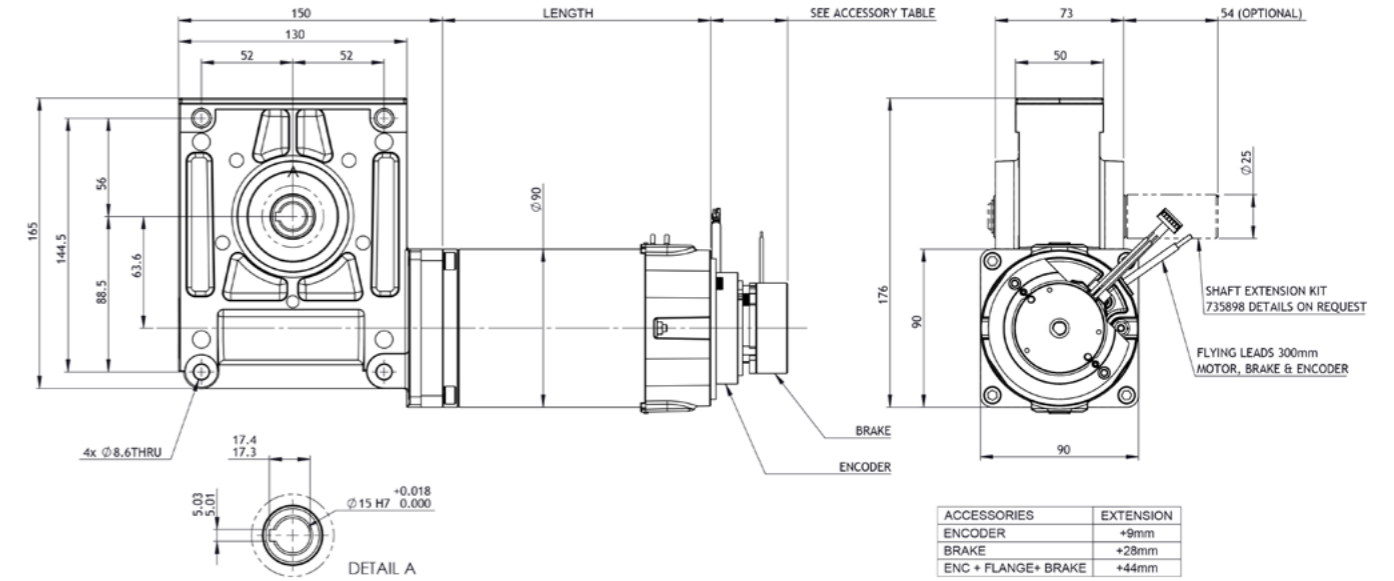

Combination data

Motor	BRx90-50	BRx90-50	BRx90-50	BRx90-75	BRx90-75	BRx90-75
Voltage	V 12 - 48	12 - 48	12 - 48	12 - 48	12 - 48	12 - 48
Nominal motor power	W 157 - 210	157 - 210	157 - 210	236 - 283	236 - 283	236 - 283
Gearbox ratio	:1 15	30	60	15	30	60
Nominal speed	rpm 200	100	50	167 - 200	83 - 100	42 - 50
Nominal torque ¹	Nm 6.4 - 8.5	11.3 - 15.1	19.5 - 26.1	11.5	20.3	35.1
Intermittent torque (S2 - 15 mins)	Nm 14.9	26.3	45.6	19.1	33.8	58.5

Motor data

Part number	781102	781103	781104	781106	781107	781108
Nominal power	W 157	210	210	236	283	283
Nominal voltage	V 12	24	48	12	24	48
Nominal speed	rpm 3000	3000	3000	3000	3000	3000
Continuous torque (S1)	Nm 0.50	0.67	0.67	0.90	0.90	0.90
Intermittent torque (S2 - 15 minutes)	Nm 1.17	1.17	1.17	1.50	1.50	1.50
Weight	Kg 3.60	3.60	3.60	4.00	4.00	4.00
Stack length	mm 50	50	50	75	75	75
Length	mm 153	153	153	183	183	183

Gearbox data

Part number	735900	735901	735902
Ratio	:1 15	30	60
Max. continuous torque (S1) ²	Nm 50.0	50.0	50.0
Max. intermittent torque	Nm 80.0	80.0	80.0
Efficiency	% 85	75	65
Max. axial load (dynamic)	N 600	600	600
Max. radial load, 12mm from flange	N 800	800	800
Weight	Kg 2.3	2.3	2.3
Gear material	Composite	Composite	Composite

² S1 duty cycle based on 3000rpm input speed

Combination accessories

Brake	Part number	Encoder	Part Number	Controller	Part Number	Shaft extension	Part number
1.5 Nm brake	735914	Incremental 5-pin	735912	SC 50/15	738590	GB9 shaft kit	735898
Mounting flange	781279	Incremental 10-pin	919386				
		Differential 10-pin	919388				

GB65 combinations

Supplied as standard with a hollow shaft, the GB65 right-angle gearbox can be integrated with our PBL86 and BRx90 modular motors.

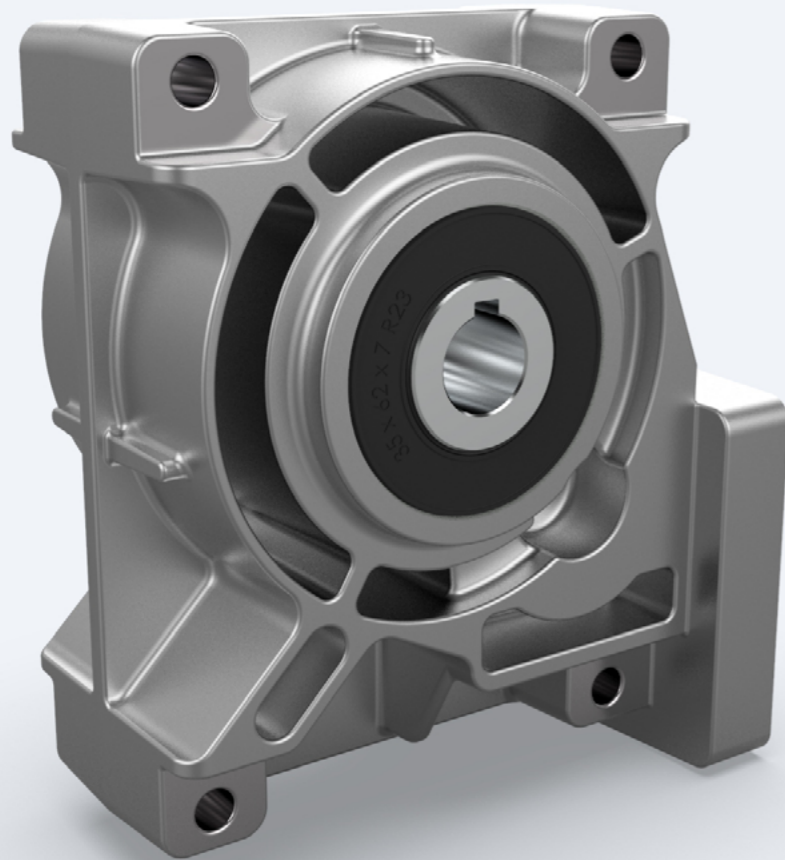

BRx90-GB65 PMDC right-angle geared motor

12 - 48 V // 157 - 283 W // 19 - 150 rpm // 8.1 - 103.2 Nm

all dimensions in mm

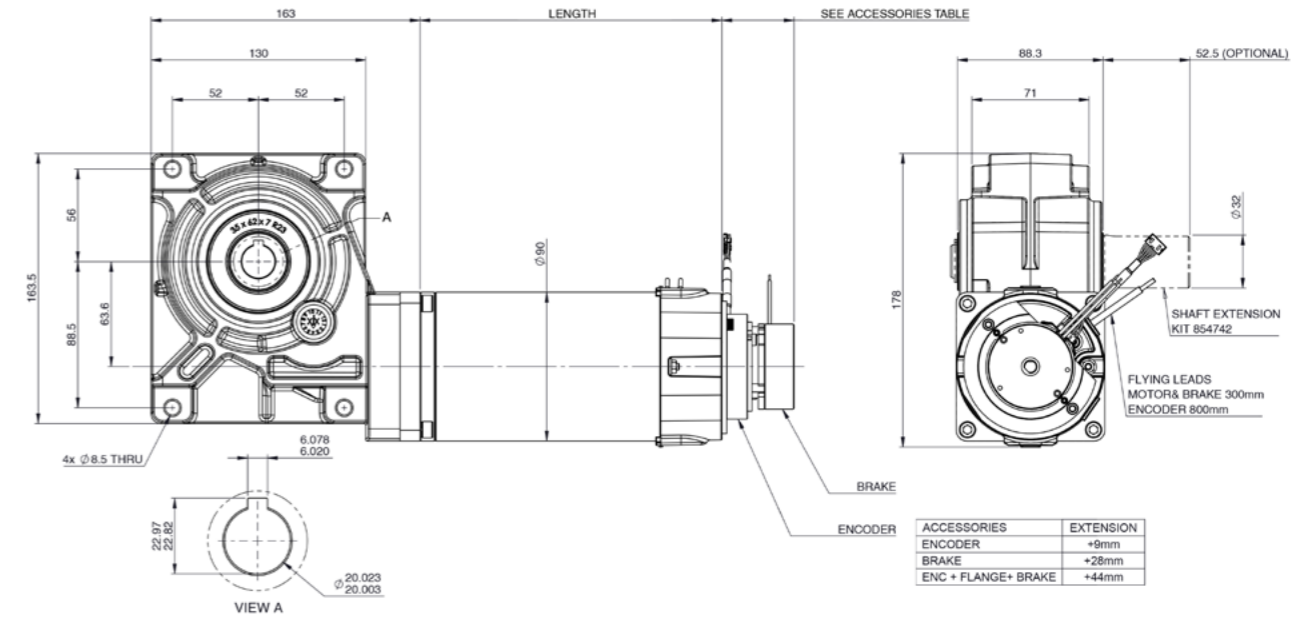

Combination data											
Motor		BRx90-50	BRx90-50	BRx90-50	BRx90-50	BRx90-50	BRx90-75	BRx90-75	BRx90-75	BRx90-75	BRx90-75
Voltage	V	12 - 48	12 - 48	12 - 48	12 - 48	12 - 48	12 - 48	12 - 48	12 - 48	12 - 48	12 - 48
Nominal motor power	W	157 - 210	157 - 210	157 - 210	157 - 210	157 - 210	236 - 283	236 - 283	236 - 283	236 - 283	236 - 283
Gearbox ratio	:1	20	40	80	120	160	20	40	80	120	160
Nominal speed	rpm	150	75	38	25	19	125 - 150	63 - 75	31 - 38	21 - 25	16 - 19
Nominal torque ¹	Nm	8.1 - 10.9	15.2 - 20.4	28.0 - 37.5	36.0 - 48.2	34.4 - 46.1	14.6	27.4	50.4	64.8	61.9
Intermittent torque (S2 - 15 mins)	Nm	19.0	35.6	65.5	84.2	80.5	24.3	45.6	84.0	108.0	103.2

Motor data							
Part number		781102	781103	781104	781106	781107	781108
Nominal power	W	157	210	210	236	283	283
Nominal voltage	V	12	24	48	12	24	48
Nominal speed	rpm	3000	3000	3000	2500	3000	3000
Continuous torque (S1)	Nm	0.50	0.67	0.67	0.90	0.90	0.90
Intermittent torque (S2 - 15 minutes)	Nm	1.17	1.17	1.17	1.50	1.50	1.50
Weight	Kg	3.60	3.60	3.60	4.00	4.00	4.00
Stack length	mm	50	50	50	75	75	75
Length	mm	153	153	153	183	183	183

Gearbox data						
Part number		854060	853270	827936	827934	827943
Ratio	:1	20	40	80	120	160
Max. continuous torque (S1) ²	Nm	120.0	120.0	120.0	120.0	120.0
Max. intermittent torque	Nm	300.0	300.0	300.0	300.0	300.0
Efficiency	%	81	76	70	60	43
Max. axial load (dynamic)	N	1750	1750	1750	1750	1750
Max. radial load, 12mm from flange	N	2335	2335	2335	2335	2335
Weight	Kg	3.5	3.5	3.5	3.5	3.5
Gear material ³		S / B	S / B	S / B	S / B	S / B

² S1 duty cycle based on 3000rpm input speed ³ Gear material: S = Steel / B = Bronze

Combination accessories							
Brake	Part number	Encoder	Part Number	Controller	Part Number	Shaft extension	Part number
1.5 Nm brake	735914	Incremental 5-pin	735912	SC 50/15	738590	GB65 shaft kit	854742
Mounting flange	781279	Incremental 10-pin	919386				
		Differential 10-pin	919388				

Modular Accessories

Fine tune your configuration

Here at Parvalux, we appreciate that sometimes it's the small things that can really make a difference, that's why we offer a range of accessories to enable more precise control of your motor-gearbox system.



Our 1.5 Nm brake can be used on our PBL60, PBL70, and PBL86 brushless motors, and our BRx63, BRx70, and BRx90 brushed motors.

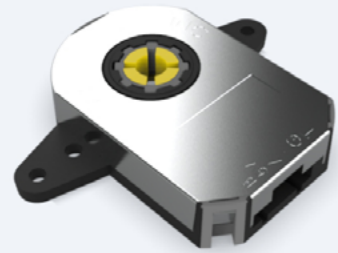

Encoders

Our modular encoder range features our incremental 5-pin, incremental 10-pin, and differential 10-pin encoders.

Integrating seamlessly with our motors by either mounting directly to the non-drive end, or through use of intelligently designed mounting flanges, the addition of an encoder to your modular selection adds that extra level of control to your system.

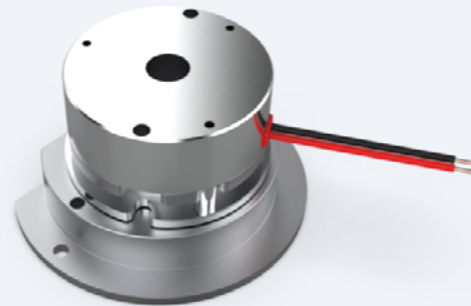

Brakes

Adding a brake to your modular configuration couldn't be easier. Mounting directly to the back of the motor, or onto a mounting flange that fits around the encoder when needed, our 1.5 Nm brake adds that extra reassurance when holding a load on your system.

Currently, the 1.5 Nm brake is only suitable for a few motors within the modular range, however, we plan to extend our brake range in the near future.



Shafts

Our current range of modular gearboxes are supplied with a hollow shaft as standard; however, we also offer shaft extension kits for both our GB9 and GB12 gearboxes.

Secured through a keyway and slot, our shaft extension kits offer a quick-fit solution where a hollow shaft isn't quite right for your application.



Controllers

Intelligent motion control can extend the possibilities of your configuration.

The Parvalux SC 50/15 controller has been developed in conjunction with our parent company, maxon, and integrates seamlessly with the PMDC and BLDC motors within the modular range.

Encoders & brakes

Our encoders and brakes integrate with your modular motor through use of intelligently designed mounting flanges and offer more precise control of your modular solution.

all dimensions in mm

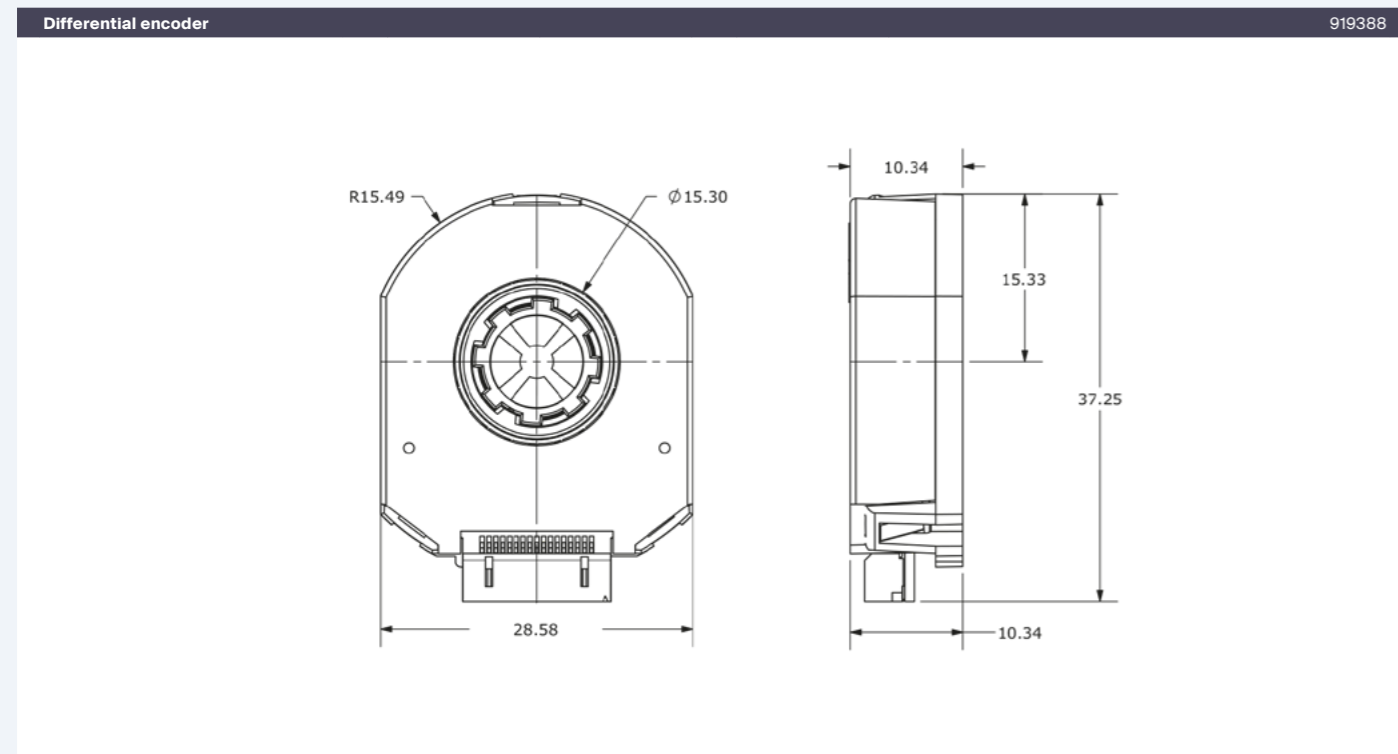
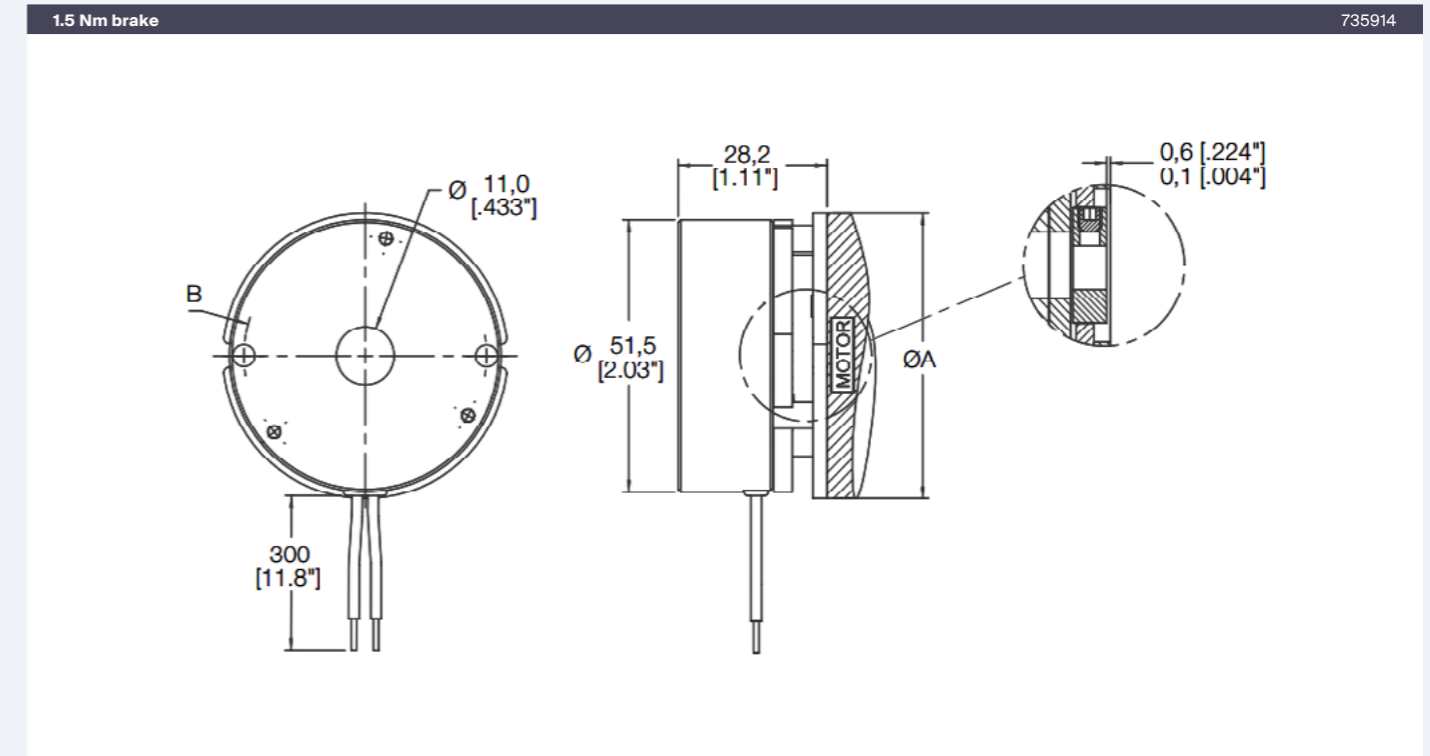
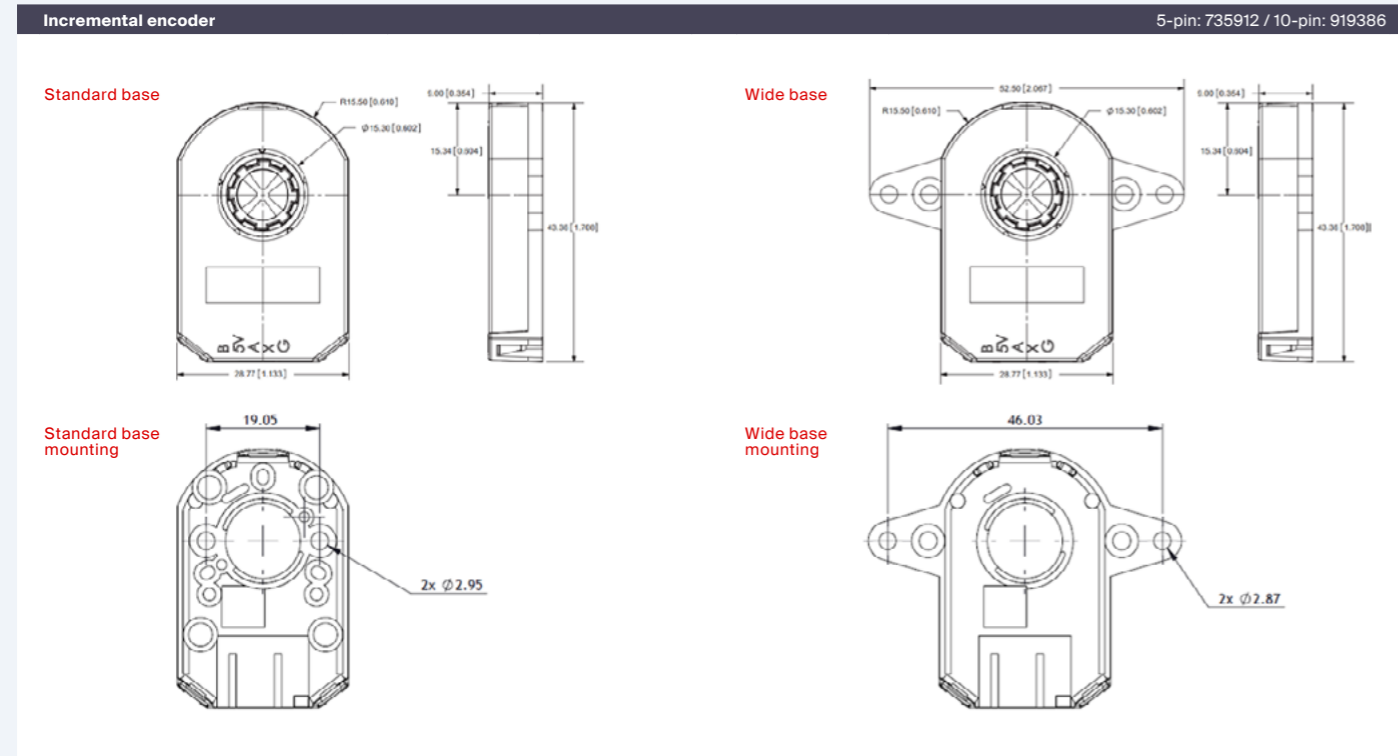

Mounting flange part numbers			
Motor	Encoder	Brake	Encoder + brake
PBL42	781280	N/A	N/A
PBL60	Direct mount	Direct mount	781281
PBL70	Direct mount	Direct mount	781281
PBL86	Direct mount	Direct mount	781284
RE38	781275	N/A	N/A
BRx42	781275	N/A	N/A
BRx52	837660	N/A	N/A
BRx63	781276	781276	865630
BRx70	Direct mount	Direct mount	781277
BRx90	Direct mount	Direct mount	781279

As shown above, our accessories mount directly to the non-drive end of several of our modular motors. However, where this is not possible, we have specific mounting flanges that enable us to combine the two together, the part numbers of which are shown in the cells above. Where 'N/A' is displayed, this signifies that these accessories cannot currently be combined with the respective motors shown.

Shaft extension kits

Our right-angle modular gearboxes are supplied as standard with a hollow shaft; however, you can add a shaft extension kit to your modular build if required.

all dimensions in mm

GB28 shaft extension kit 735908

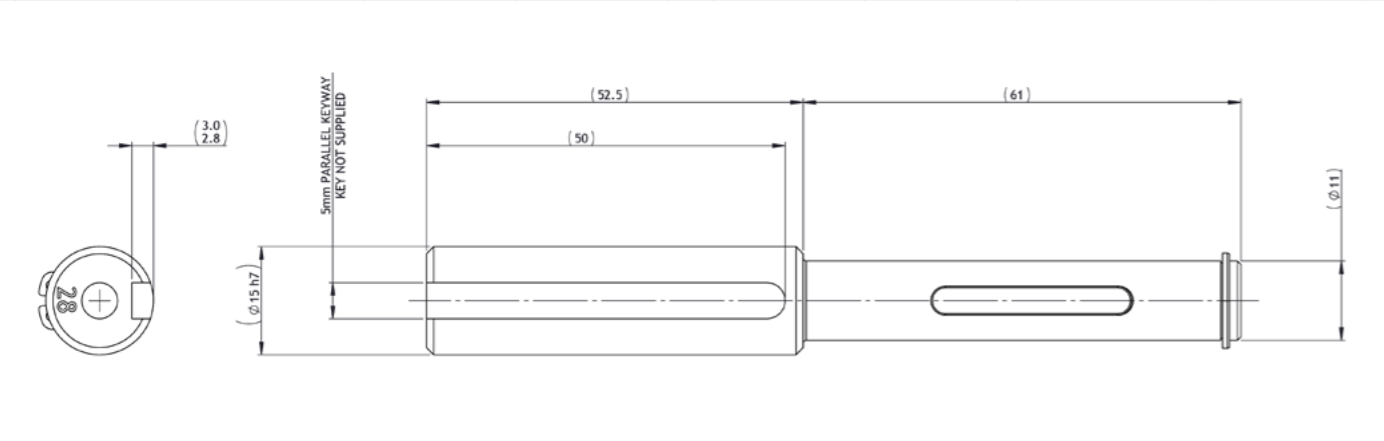

GB9 shaft extension kit 735898

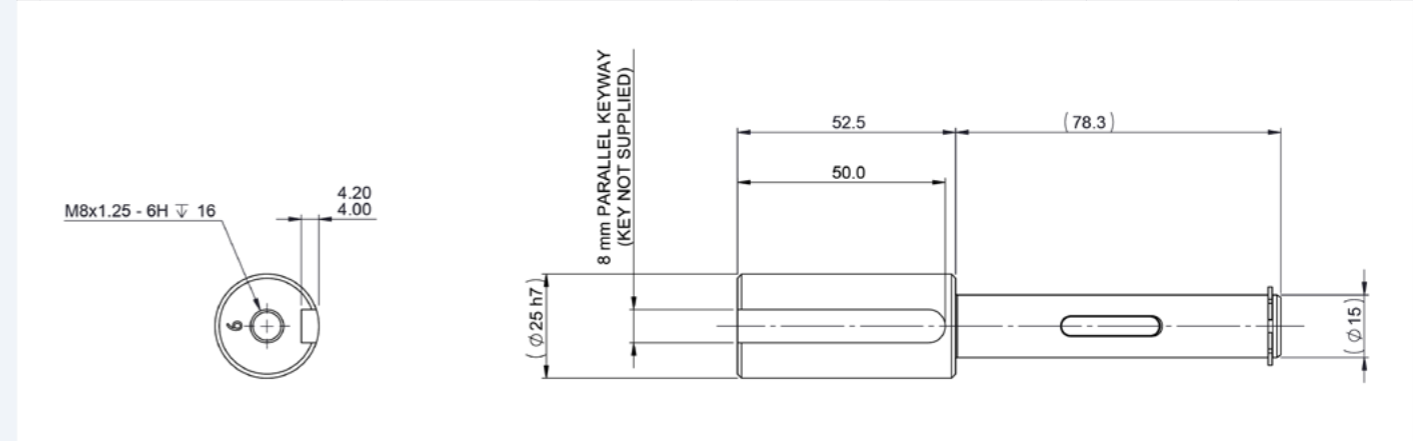

GB80 shaft extension kit

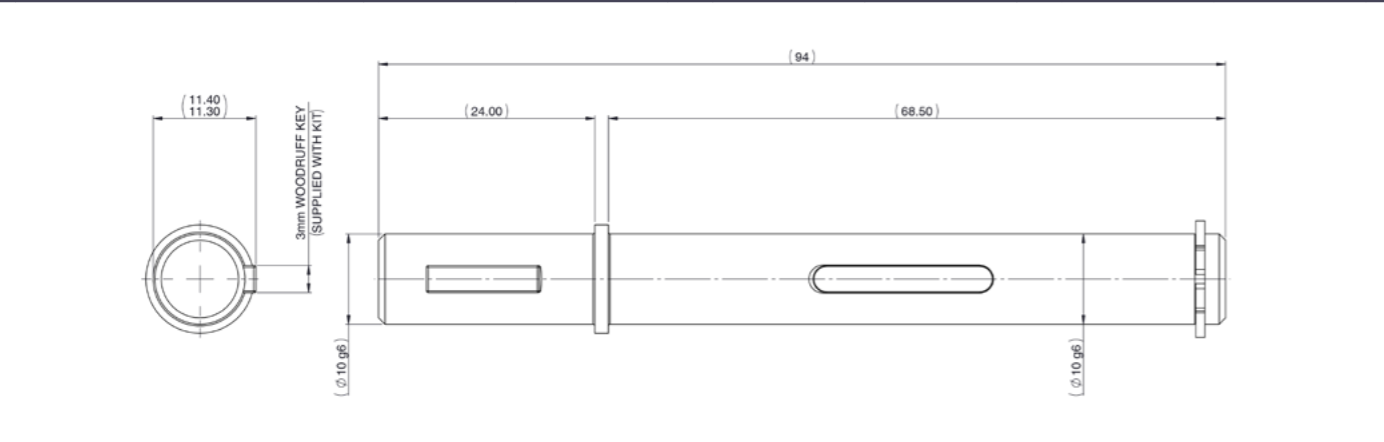

GB65 shaft extension kit 854742

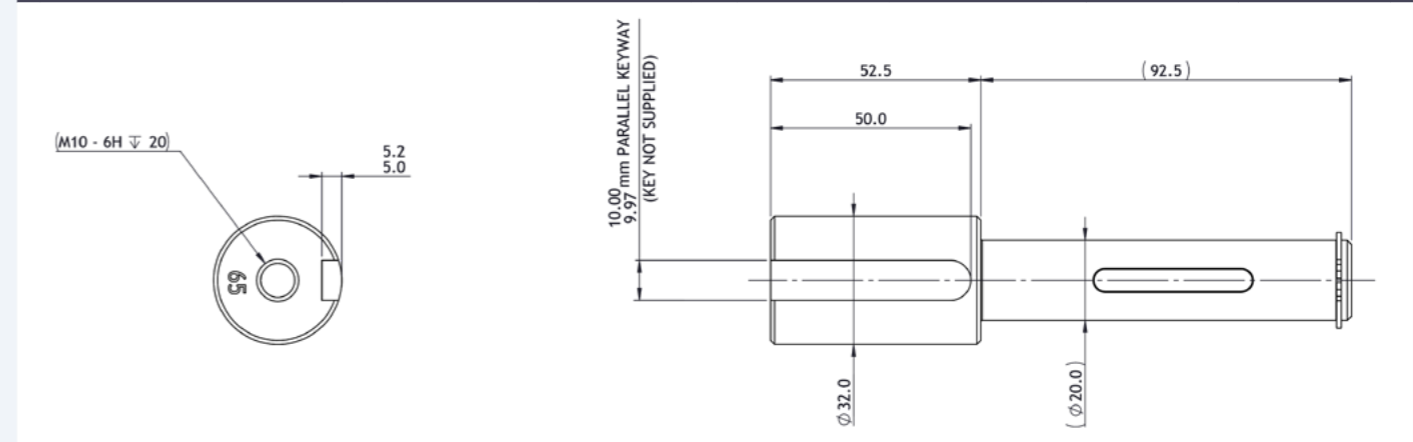

GB12 shaft extension kit 735903

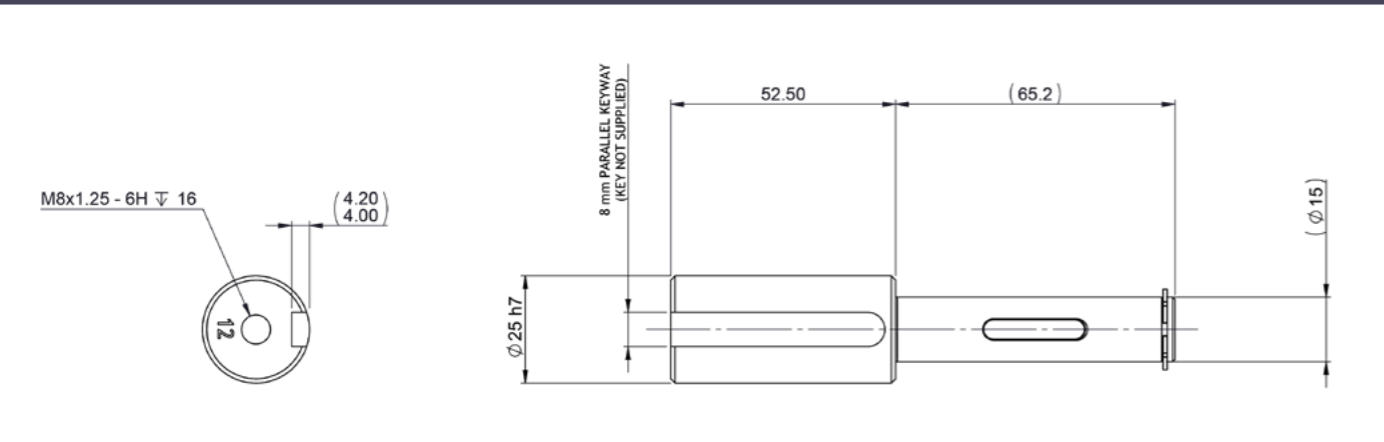

The modular range offers a quicker route to proof-of-concept than our standard range due to each component being kept in stock, ready for assembly when you place your order. As such, it may be the case that our shaft extension kits may not meet the exact requirements of your application, however, they will offer a starting point that will allow you to conduct testing with your modular solution.

Once proof-of-concept has been obtained and your project is ready to progress to a higher quantity production, our in-house team of design engineers are well-versed in creating a custom shaft that meets your exact specification.

SC 50/15 controller

738590

all dimensions in mm

Electrical rating		
1 Nominal power supply voltage +V _{cc}	VDC	12 - 50
2 Absolute supply voltage +V _{min} / +V _{max}	VDC	10 / 56
3 Output voltage (max.)	V	0.98 x +V _{cc}
4 Output current I _{cont} / I _{max} (< 10 s)	A	15 / 30
5 Pulse width modulation frequency	kHz	53.6
6 Sampling rate PI speed controller	kHz	5.36
7 Max. efficiency	%	98
8 Max. speed - PMDC motor	Open loop: limited by max. permissible speed (motor) and max. output voltage (controller) Closed loop: 5000 to 15,000 rpm, dependent on configuration	
9 Max. speed - BLDC motor	2500 ... 30,000 rpm, dependent on configuration	
10 Built-in filter choke	nH; A	3 x 200; 15

Inputs and outputs		
1 Digital input - «Enable»	Logic +2.1 ... +30 VDC	
2 Digital input - «Direction»	Logic +2.1 ... +30 VDC	
3 Digital input - «Stop»	Logic +2.1 ... +30 VDC	
4 Digital output - «Ready»	Logic signal output, 3.3 VDC, Ri: 2.2 kΩ, Push-Pull	
5 Analog input - «Speed set value»	PWM signal (fixed amplitude 0 ... 5 VDC, 1 kHz ... 10 kHz)	
6 Digital hall sensors H1, H2, H3	+2.0 ... +24 VDC (internal pull-up)	
7 Digital incremental encoder signals A, A', B, B'	EIA RS422, max. 1 MHz, max. 100 kHz (single-ended)	

Voltage outputs		
1 Sensor supply voltage V _{sensor}	+5 VDC / I _L ≤ 100 mA	

Motor connections		
1 PMDC motor	+ motor, - motor	
2 BLDC motor	Motor winding 1, motor winding 2, motor winding 3	

Configuration		
1 DIP switch	SMD type, 8 position for the setting of: <ul style="list-style-type: none"> • Motor Type • Control Mode • Speed Set Value Source • Speed Sensor Selection / Encoder Resolution • Hall Sensor Polarity • Speed Range Selection 	

2 Potentiometers	3 x angular type 210° for the setting of: <ul style="list-style-type: none"> • Speed Ramp/Speed Set Value • Continuous/Maximum Current Limit • Controller Gain 	
------------------	---	--

Status indicators		
1 Device status - Operation	Green LED	
2 Device status - Error	Red LED	

Physical		
1 Weight	g	151
2 Dimensions (L x W x H)	mm	100.0 x 80.0 x 22.2
3 Mounting	Slotted flange for M4 screws	

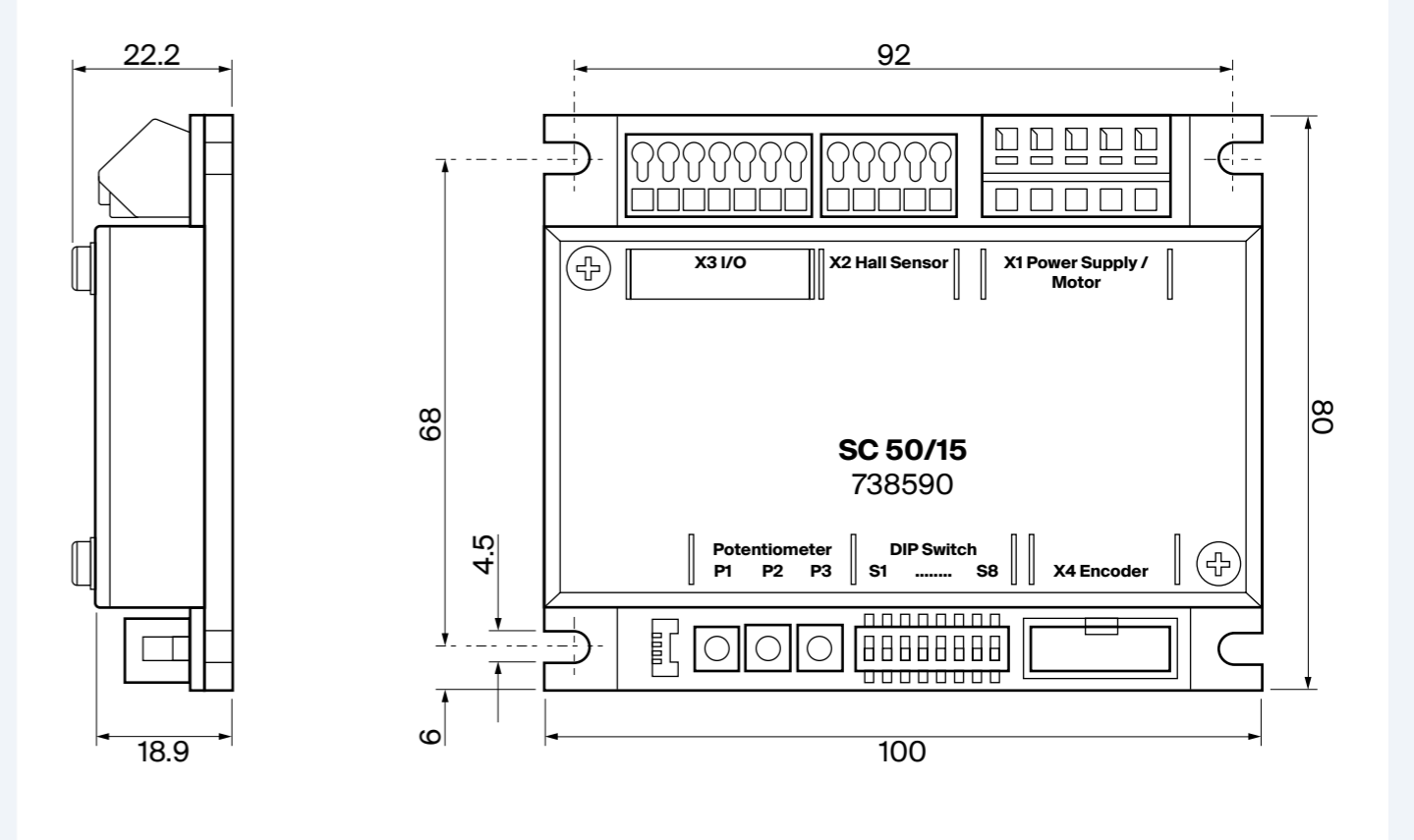

Environment		
1 Temperature - Operation	°C	-30 ... +30
2 Temperature - Extended range [a]	°C	+30 ... +84; Derating: -0.278 A/°C
3 Temperature - Storage	°C	-30 ... +85
4 Altitude [b]	m	0 ... 6000 MSL
5 Humidity	%	5 ... 90 (condensation not permitted)

[a] Operation within the extended range is permitted. However, a respective derating (declination of output current I_{out}) as to the stated values will apply. [b] Operating altitude in meters above Mean Sea Level, MSL.

Thermal data

Derating of output current

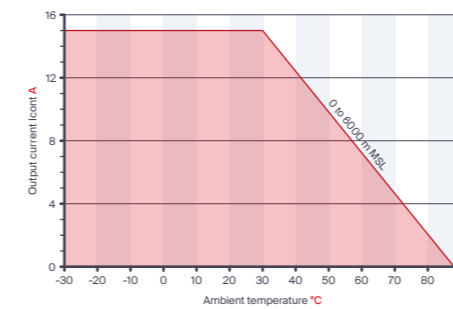

Power dissipation and efficiency

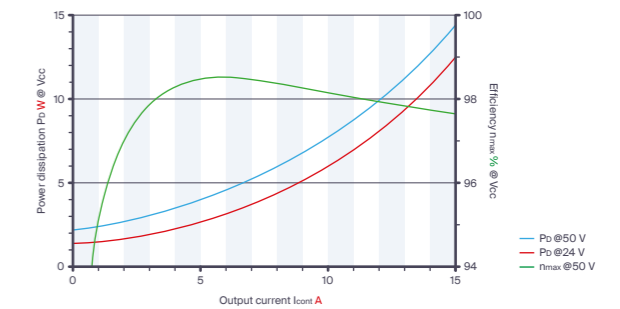

Building Automation

Recommended Combinations

Building automation touches many people's lives, often without them even realising. Revolving, hinged or sliding security points, elevator doors, car park barriers, roller blinds, CCTV, and HVAC applications all fall under the building automation umbrella and each application requires reliable motor drives in order to function.

Electric door manufacturers are increasingly seeking greater efficiency in door motor drive units, as well as needing long-term reliability and durability. Parvalux delivers on all fronts with a range of AC and DC brushed and brushless geared motors trusted globally in buildings and on mass transit systems, such as train, bus and elevator doors.

Access control systems such as security barriers, swipe card or proximity entry points in office buildings benefit from leveraging IoT (Internet of Things) technologies; however, these essential functions are only effective when allied to reliable and durable motor drives.

With an expanding population all over the world, ease of access in public places is of paramount importance in ensuring the efficient and safe movement of people from one place to another. This in turn has seen growth in the need for reliable building automation solutions in a number of applications worldwide. With a higher level of competition in this sector, the Parvalux modular range can provide a quicker route from concept to manufacture, enabling you to gain an advantage against your competitors.

We also have extensive experience in providing geared motor solutions to a number of different door automation applications, such as;

- Access control
- Shutter and blind closers
- Pool cover closers



Door automation

PMDC	BLDC
RE38-PGx42	PBL42-PGx42
BRx42-PGx42	PBL60-GB80
BRx52-GB80	
BRx63-GB80	
BRx70-GB80	
BRx70-GB12	
BRx90-GB12	



Access control

PMDC	BLDC
RE38-PGx42	PBL42-PGx42
BRx42-PGx42	PBL60-GB80
BRx52-GB80	
BRx63-GB80	
BRx70-GB80	
BRx70-GB12	
BRx90-GB12	

💡 Recommended combinations for these applications will be added in the near future. Please contact our sales team if assistance is needed in selecting your solution.

Materials Handling

Recommended Combinations

The modern warehouse sector has embraced motorised automated material handling equipment to support employee safety and drive efficiency. Parvalux has significant experience supporting some of the largest and most innovative intralogistics equipment manufacturers.

Since the start of the pandemic, there has been meteoric growth in online shopping, most of this being fulfilled via large, complex warehousing and distribution hub facilities. Parvalux was able to react quickly with standard and custom gear motor designs for conveyor belt systems, picking systems, parcel sorting equipment, pallet shuttles and automated storage and retrieval systems (ASRS).

The Parvalux modular range includes a number of different combinations that are well suited to many of the applications found in this fast paced and rapidly developing industry. When the demand for a quick turnaround to take a concept to market is at an all time high, our modular range solutions can provide the perfect starting point for proof of concept, which can later be customised to meet your exact requirements.

We also have extensive experience in providing geared motor solutions to a number of different materials handling applications, such as;

- Automated shrink wrapping
- Pallet and tray shuttles
- Sorting machines

 Recommended combinations for these applications will be added in the near future. Please contact our sales team if assistance is needed in selecting your solution.



Conveyors

PMDC	BLDC
BRx70-GB12	PBL42-PGx42
BRx90-GB12	PBL60-GB80
BRx90-GB9	PBL70-GB12
BRx90-GB65	PBL86-GB12
	PBL86-GB9
	PBL86-GB65



ASRS

PMDC	BLDC
BRx70-GB12	PBL42-PGx42
BRx90-GB12	PBL60-GB80
BRx90-GB9	



AGVs

PMDC	BLDC
BRx70-GB12	PBL42-PGx42
BRx90-GB12	PBL60-GB28
BRx90-GB9	PBL60-GB80
	PBL86-GB9



Warehouse tugs

PMDC	BLDC
BRx70-GB12	PBL70-GB12
BRx90-GB12	PBL86-GB12
BRx90-GB9	PBL86-GB9
BRx90-GB65	PBL86-GB65

Mobility solutions

Recommended Combinations

It's a fact of life that advances in healthcare mean people are now living longer and as we age, we become more reliant on mobility products to support independent living. Our ability to travel, go shopping, take outdoor recreation and even play sports can be extended with the help of a range of mobility solutions.

Parvalux has demonstrable experience providing reliable and robust drive systems for a range of mobility products, from electric wheelchairs to mobility scooters and even golf buggies and carts. Manufacturers benefit from our ability to customise our geared motor products to meet their specific need and our willingness to develop fully custom solutions, where required.

The Parvalux modular range includes a number of different combinations that are well suited to many of the applications found in this ever-growing industry.

Although many of the solutions we provide for this sector usually require some customisation, our modular range can be utilised to quickly provide proof of concept for a range of mobility solution projects.

We also have extensive experience in providing geared motor solutions to a number of different materials handling applications, such as;

- Mobility scooters
- Mobility vehicles
- Powered wheelchairs
- Taxi step actuators
- Wheelchair ramps

 Recommended combinations for these applications will be added in the near future. Please contact our sales team if assistance is needed in selecting your solution.



Stairlifts

PMDC	BLDC
BRx70-GB12	PBL70-GB12
BRx90-GB12	PBL86-GB12
BRx90-GB9	PBL86-GB9
BRx90-GB65	PBL86-GB65



Patient hoists

PMDC	BLDC
BRx52-GB80	PBL60-GB28
BRx63-GB80	PBL60-GB80
BRx63-GB28	PBL70-GB12
BRx70-GB80	
BRx70-GB12	
BRx90-GB12	



Platform lifts

PMDC
BRx70-GB12
BRx90-GB12
BRx90-GB9



Wheelchair lifts

PMDC	BLDC
BRx70-GB12	PBL70-GB12
BRx90-GB65	PBL86-GB65

Your next steps

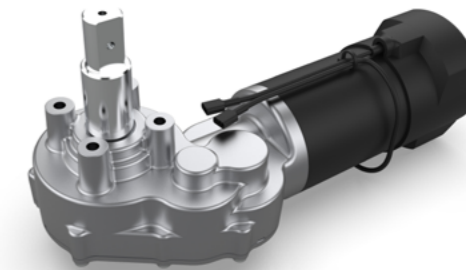

Start building

If you're ready to start building your modular solution visit parvalux.com/modular-range or scan the QR code to the right.

Here, you can choose to start your modular build from a motor, gearbox, or motor-gearbox combination, or select one of our recommended combinations for specific applications.

This will take you to our online configurator where you can add accessories and order your build in quantities of up to 10 pieces, all on a 72-hour turnaround!



Standard range

If you can't find anything within the modular range that meets your requirements, we have an extensive range of standard motors and gearboxes that can be found within our product range catalogue.

Visit parvalux.com/catalogues to explore the range

Custom solutions

Our expert team of design engineers are well-versed in modifying our standard range to suit or can even create a completely custom solution from scratch.

Visit parvalux.com/custom-drive-solutions to take a look at some of our previous creations



If you require any further information about the modular range, standard products, or custom drive solutions we offer, our friendly team of sales engineers are on-hand to answer any questions you may have. Discuss the requirements of your project with your local sales engineer, found on the next page.

Made in the UK...

...Available Worldwide

Parvalux products are used in a range of different industries all over the world, so it's important that we can support you, wherever you may be.

Our global network ensures that we can answer your questions quickly and clearly, and, of course, get your order to you as soon as possible.

America

 **USA (East Coast)**
maxon precision motors, inc.
125 Dever Drive, Taunton, MA 02780, USA
sales.us@maxongroup.com // +1/508-916 6620

 **USA (West Coast)**
maxon precision motors, inc.
2860 Zanker Rd. Suite 107, San Jose, CA 95134, USA
info.us@maxongroup.com // +1/650-524-8822

 **Mexico**
maxon mexico
Av. de las Americas 1501, Piso 21, nom. 2130, Col. Providencia 44630,
Guadalajara, Jalisco, Mexico
ventas.mx@maxongroup.com // +52 81 2188 1940

 **Brazil**
Treffer Ltda. (maxon sales agent)
AV. Protásio de Oliveira Penna 366 / 101, Cep 30575-360 Bairro
Buritis, Belo Horizonte - MG, Brazil
motores@treffer.com.br // +55 31 3378 6222

 **Canada**
Electromate Inc. (maxon sales agent)
6221 Highway 7, Unit #15, Vaughan, Ontario L4H 0K8, Canada
sales@electromate.com // +1/877 737 8698

Europe / Middle-East / Africa

 **Austria, Hungary, Slovenia, Romania, Croatia, Serbia, and Bulgaria**
Kwapil & Co GmbH
Kammellweg 9, 1210 Wien, Austria
verkauf@kwapil.com // +43/1 - 278 85 85

 **Czech Republic and Slovakia**
Kwapil & Co. Gesellschaft m.b.H
Hlavní 1054/131, 624 00 Brno, Czech Republic
sales@kwapil.com // +420 541 211 538

 **Denmark**
DJ Stork Drives ApS
Naverland 2, 10., 2600 Glostrup, Denmark
ulrik.eriksen@storkdrives.com // +45 8988 2416

 **Finland, Estonia, Latvia, and Lithuania**
DJ Stork Drives OY
Mököistenkatu 2, 241 00 Salo, Finland
jyrki.leinonen@storkdrives.fi // +358 45 11 06 433

 **France**
maxon France
201 - 715 rue du Chat Botté, 01700 Beynost, France
contact.fr@maxongroup.com // +33/472 - 018 300

 **Germany**
maxon motor gmbh
Truderinger Strasse 210, 81825 München, Germany
sales.de@maxongroup.com // +49/89 - 42 04 93 - 0

 **Great Britain and Ireland**
maxon motor uk Ltd.
maxon House, Hogwood Lane, Finchampstead, Berkshire, RG40 4QW, UK
sales.uk@maxongroup.com // +44 (0) 1189 733337

 **Israel**
maxon motor Israel Ltd.
Leshem Industrial Park 6, P.O. Box 3094, Caesarea 3079870, Israel
sales.il@maxongroup.com // +972 74 749 0888

 **Italy**
maxon motor italia S.r.l.
Società Unipersonale, Via Sirtori 35, 20017 Rho MI, Italy
sales.it@maxongroup.com // +39 02 93580588

Europe / Middle-East / Africa

 **Netherlands, Belgium, and Luxembourg**
maxon motor benelux bv
Josink Kolkweg 38, 7545 PR Enschede, Netherlands
sales.nl@maxongroup.com // +31 53 744 07 44

 **Norway**
DJ Stork Drives AS
Garverivegen 6, 2740 Roa, Norway
arve.stensrud@storkdrives.com // +47/6199 3001

 **Poland**
maxon Polska sp. z o.o
Poznań Technology and Industry Park, 28 Czerwca 1956 r. 404, 61 - 441
Poznań, Poland
sprzedaz@maxongroup.com // +48 618 800 830

 **Spain and Portugal**
maxon motor iberica
C/ Polo Norte N° 9, 28850 Torrejón de Ardoz, Spain
info.es@maxongroup.com // +34 916 564 973

 **Sweden and Iceland**
Stork Drives AB
Box 1158, Solna Strandväg 116, 171 54 Solna, Sweden
info@storkdrives.se // +46/8 - 635 60 00

 **Switzerland**
maxon Switzerland ag
Industriestrasse 23, 6055 Alpnach, Switzerland
sales.ch@maxongroup.com // +41 (0) 41 662 95 95

 **South Africa**
DNH Technologies
P.O. Box 31151, 1684 Kyalami, South Africa
info@dnhtrade.co.za // +27 11 468 2722

 **Turkey**
Ensatek Muhendisilik Otomsyon Sanayi Ticaret Limited Sirketi
Cevizli Mah. Mustafa Kemal Cad. No: 66/B, Kat: 13 D : 88 34865
Kartal/Istanbul, Turkey
ensatek@ensatek.com.tr // +90 216 510 88 64

Pacific

 **Australia and New Zealand**
maxon motor australia Pty Ltd
Unit 1, 12-14 Beaumont Road, Mount Kuring-Gai, NSW 2080, Australia
sales.au@maxongroup.com // +61 2 9457 7477

Asia

 **China**
maxon motor (Suzhou) Co., Ltd.
5F, Block 1 No. 1128, East Jiangxing Road, Wujiang Economic
Developing Zone, 215200 Suzhou, Jiangsu Province, China
sales.cn@maxongroup.com // +86/512-8207 9287

 **India**
maxon precision motor India Pvt. Ltd.
Niran Arcade, No. 563/564, New BEL Road, RMV 2nd Stage,
Bangalore - 560 094, India
sales.in@maxongroup.com // +91 80417 34132

 **Japan**
maxon Japan
5-1-15 Shinjuku, Shinjuku-Ku, Tokyo 160-0022, Japan
sales.jp@maxongroup.com // +81/3 - 3350 42 61

 **South Korea**
maxon motor Korea Co., Ltd.
27, Banpo-daero 14-gil, Seocho-Gu, Seoul, South Korea 06652
info.kr@maxongroup.com // +82 2 3486 3441

 **Singapore**
maxon motor SEA Pte. Ltd.
33 UBI Avenue 3 #08-40, Singapore 408868
admin.sg@maxongroup.com // +65/6950 4628

 **Taiwan**
maxon motor Taiwan Co. Ltd.
6F.-7 No. 16, Lane 609, Sec. 5, Chongxin Rd., Sanchong Dist., New
Tapei City 241, Taiwan (R.O.C.)
sales.tw@maxongroup.com | +886-2-2999-3558

 **Hong Kong**
Servo Dynamics (H.K) Ltd.
Rm. 1504, 15/F, Yuen Long Trading Centre, 33 Wang Yip Street West,
Yuen Long, N.T., Hong Kong
sales.servodynamics.com.hk // +852/2409 9986

 **Malaysia**
Servo Engineering Sdn. Bhd.
No. 15 G, Ground Floor, Highway Center, Jalan 51/205, 46050 Petaling
Jaya, Selangor Darul Ehsan, Malaysia
sales-rfq@servo.my // +603-7782 3540

 **Thailand**
Servo Dynamics (Thailand) Co. LTD
52/210 Moo 2, Soi Wadnamdaeng, Srinakarini Rd. 10540 Bangkaew
Bangplee Samutprakarn, Thailand
dmk@servoline.com // +66 2 753 56 25

parvalux

by **maxon**



Our expert team of design engineers are also well-versed in customising our standard range or creating a fully custom solution from scratch. Get in touch today to discuss your requirements.

Can't find what you're looking for?

Our standard range of products include additional options for PMDC, BLDC and AC motors, as well as right-angle and inline gearboxes.

Visit www.parvalux.com to explore the entire range.

