

# PBL86-80 BLDC motor

Ø86 mm frame // 80 mm stack

**parvalux**  
by **maxon**

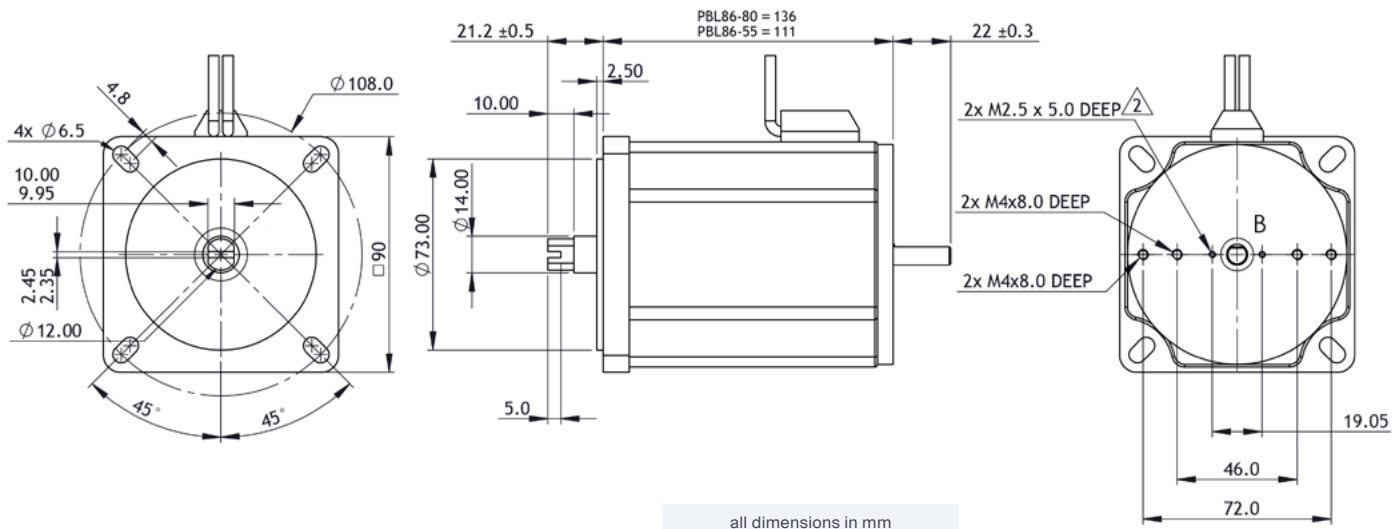

all dimensions in mm

Part number key	
Modular	#####
Standard	#####
Calculated data	#####

Technical data			Connection details		
1 Part number		776625	Lead colour	Lead gauge	Function
2 Nominal power	W	586	Red	UL1569/26 AWG	VCC
3 Nominal voltage	V	48	Black	UL1569/26 AWG	GND
4 No load speed	rpm	4192	Blue	UL1569/26 AWG	Hall A
5 No load current	A	1.9	Green	UL1569/26 AWG	Hall B
6 Nominal speed	rpm	4000	White	UL1569/26 AWG	Hall C
7 Nominal continuous torque (S1)	Nm	1.4	Red	UL1569/14 AWG	Phase U
8 Nominal continuous current (S1)	A	14.4	Yellow	UL1569/14 AWG	Phase V
9 Max Intermittent torque (S2 - 15 minutes)	Nm	2.45	Black	UL1569/14 AWG	Phase W
10 Stall current	A	116			
11 Stall torque	Nm	12.7			
12 Stack length	mm	80			
13 Maximum efficiency	%	83			
14 Ra	Ω	0.057			
15 RI	mH	161.3			
16 Speed constant	rpm/V	879			
17 Torque constant	Nm/A	0.11			
18 Speed torque gradient	rpm/Nm	345.6			
19 Rotor inertia	Kgm <sup>2</sup>	2.9 x 10 <sup>-4</sup>			
20 Weight	Kg	4.20			

Thermal data			Modular system					
21 Ambient temperature	°C	40	<b>Gearbox</b>	<b>+L mm</b>	<b>Brake</b>	<b>+L mm</b>	<b>Encoder</b>	<b>+L mm</b>
<b>Mechanical data</b>			GB9	138.0	1.5 Nm	28.2	Incr. 5-pin	9.0
22 Radial load [distance from flange]	N [mm]	350 [15]	GB12	110.0	2.0 Nm	32.4	Incr. 10-pin	9.0
23 Radial play	mm [g]	0.06 [450]	GB65	151.0	4.0 Nm	27.7	Diff. 10-pin	12.0
24 Axial end play	mm [g]	0.08 [450]	PGx70	58.0 - 80.0	Power-on	26.4	Magnetic	12.0
<b>Other data</b>			<b>Controller</b>			<b>Key</b>		
25 Number of poles		8	SC 50/15				Standard combination	
26 Winding type		Delta	ESCON				Modular combination	
27 Hall effect angle (electrical angle)	°	120	EPOS					
28 IP Rating		IP54						
29 Enclosure		Enclosed						
30 Insulation Class		B						

+L mm = approximate added length\*

\*additional length may also be required for mounting flange between components